

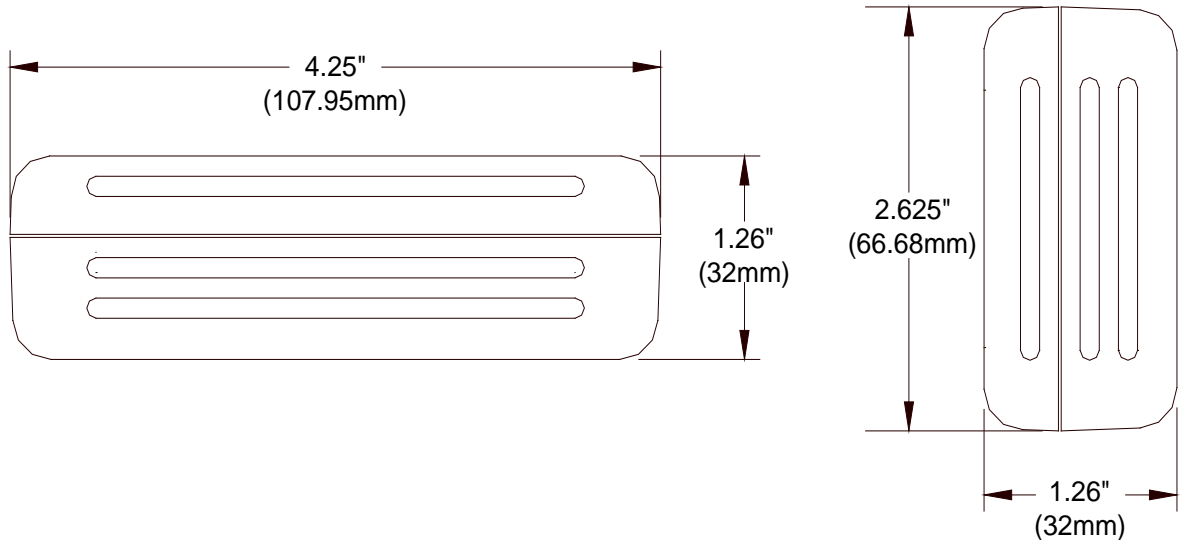

Installation and Operation Instructions WH2630AR/P, WT2630AR/P, & BR/P Wireless Humidity and Temperature Wall Sensors



General Description

The WH2630 and WT2630 are battery operated spread spectrum wireless wall humidity temperature sensors housed in a rugged enclosure.

ACI's mesh network Series 2000 wireless sensors utilize reliable Spread Spectrum Radio technology. They can be installed easily in minutes eliminating hundreds of feet of wire and saving installation cost while reducing installation labor risks.

The Series 2000 sensor Data-Link LED confirms the data transmission was received by the receiver for fast and reliable positioning of the sensor during installation. *There is no need for special wireless installation equipment or tool.*

Together with the ACI Series 2000 receivers and controllers, the ACI wireless sensors can be used with any LON, BacNet, MODbus, or DDC control system or panel.

The maximum radio transmission distance is dependent on the building type. The maximum open air transmission distance is one mile. In a typical commercial building with steel I-Beam construction, concrete floors with reinforcing rod, and metal stud walls, it can be expected that transmissions will penetrate vertically through floors and horizontally through 200 to 500 feet of walls, furniture and air.

Installation

Wireless sensors should be installed within 200 to 500 feet of the receiver. RR2552 signal repeaters can be installed as to increase transmission distance between sensors and receivers.



CAUTION

Observe battery polarity when installing battery.

To select the proper sensor location, *first install and power the receiver. To activate the sensor insert the battery observing the polarity.* The mesh networked Series 2000 system does not require any additional wireless equipment to determine the proper location of the sensors.

While the sensor is attempting to connect to the receiver the Data-Link LED will blink rapidly 8–10 times every 10 seconds. Once a connection has been established the Data-Link LED will blink once to indicate the data transmission has been received successfully. The Data-Link LED will continue to blink once for every data transmission. The data transmission rate is programmed into the sensor (normally 1 minute intervals). To manually initiate a data transmission press the push button switch located by the negative terminal of the battery.

Once the sensor location has been determined mount the sub-base on an inside wall approximately 4.5 feet from the floor (or in the specified location) to allow exposure to the average zone temperature using two #8 screws, Velcro™ or double sided tape.

Locate and record the sensor ID numbers located on a label inside the unit prior to mounting

Do not mount the sensors on an outside wall, on a wall containing water pipes or near air ducts. Avoid locations that are exposed to discharge air from registers or radiation from lights, appliances, or the sun.

Attach the wall sensor to the sub-base by tightening the two locking screws at the bottom of the sub-base.

NOTE: The locking screw must be installed for a secure installation. The screws are turned counter-clockwise to secure the cover.

The sensor has a Low Battery LED that will start to blink continuously when the battery voltage is low. A low battery signal is also sent to the receiver for remote indication that the battery should be replaced. If the battery is not replaced in approximately 2 months the battery voltage will become so low that the Low Battery and Data-Link LEDs will not blink. Replace the battery and the Data-Link LED will start blinking while the sensor is re-establishing communications with the receiver.



PRECAUTIONS

SENSORS, REPEATERS AND RECEIVERS SHOULD NOT BE INSTALLED IN THE FOLLOWING AREAS:

- **INSIDE METAL ENCLOSURE / PANEL**
- **INSIDE OR IMMEDIATELY NEXT TO ELEVATOR SHAFT / ELEVATOR BANKS**
- **IN FRONT OF OR IMMEDIATELY NEXT TO LARGE TREES OR LARGE BODY OF WATER**

TRANSMISSION DISTANCE AND PERFORMANCE WILL BE DRASTICALLY REDUCED.



CAUTION

**DO NOT USE THIS PRODUCT IN ANY SAFETY RELATED APPLICATIONS
WHERE HUMAN LIFE MAY BE AFFECTED.**

PRODUCT SPECIFICATIONS

Supply	Voltage	(1) Li/MnO2 3.0 VDC Battery, 1400 mAh (e.g. Duracell DL123A)
RF	Data Protocol	IEEE 802.15.4-2003/2006
	Operating Frequency	902-928 MHz
	Output Power	+11 dBm
	Receiver Sensitivity	-110 dBm
	Open Field Range	One mile (line of sight)
	Data Transmission Interval	75 seconds (standard), 300 seconds (option)
Temperature	Accuracy	± 1°F
	Sensor Operating Range	32 to 104°F (0 to 40°C)
Humidity	Accuracy	±3% RH
	Sensor Operating Range	10 to 90% RH
Features	User Interface	External Link Button (optional)
Enclosure	Material	ABS (standard and ruggedized)
	Rating	UL 94 HB (standard), UL 94 5VA (ruggedized)
Environment	Operating Temperature	32 to 104°F (0 to 40°C) standard 32 to 140°F (0 to 60°C) ruggedized
	Operating Humidity	0 to 95% RH (non-condensing)
Approvals		FCC

WARRANTY SPECIFICATION

The ACI Wireless Series is covered by ACI's Two (2) Year Limited Warranty, which is located in the front of ACI'S SENSORS & TRANSMITTERS CATALOG or can be found on ACI's web site: www.workaci.com.

WH2630ARP / WH2630BRP / WT2630AR/P

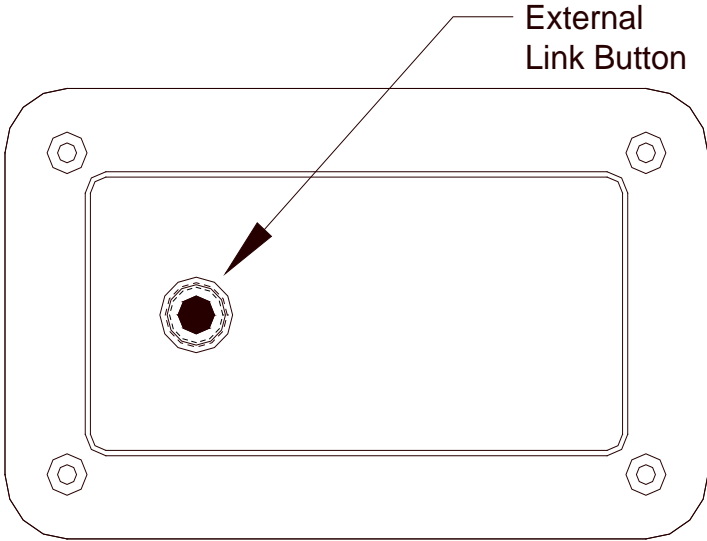

Top View