



FEATURES

- Three styles of pulses (One Shot, Looped, and Duty Cycle.)
- AC/DC capabilities (for both output pulses and supply power.)
- Pulse times selectable from 0.001 seconds to 999.99 hours.
- Analog, DC output (Current 0-20 mA DC, Volt 0-10 VDC, each with 255 steps of resolution)
- Toggle between Minimum and Maximum output values, or use one output value.
- LCD Display is adjustable for contrast. Opening on left side for (small) screwdriver adjustment.
- ON/OFF switch (located on right side)

GENERAL DESCRIPTION:

The PSG will generate several styles of pulses or two types of analog signals. A menu system displayed on its LCD screen leads you through the possible setup parameters. The PSG has a 16-button keypad to set the output values.

- PULSE TYPES: 1) Signal One Shot pulse
2) Continuously Looped on/off pulse
3) Duty Cycle pulse

One Shot and Looped Pulse modes can be set in Time Units of seconds, minutes or hours. Duty Cycle pulse mode can be set in Time Units of seconds only

- ANALOG TYPES: 1) Current
2) Voltage

KEYPAD DESCRIPTION:

The PSG has eleven keys, labeled 0-9 and period '.', used to set output values. Several other keys have multiple purposes.

The YES/UP and the NO/DOWN keys are used to ramp the output (up or down) and to switch between options presented on the LCD. Both keys are used to move between choices displayed on the LCD signifying that the user would like to change the selected option. Note that the UP and DOWN keys will ramp the output only while generating a Duty Cycle pulse, or a Current or Voltage output.

The BACK key is used to move back to previous menu choices or to correct a number that was entered incorrectly. Scrolling backwards through the menus can be done only until you arrive at a screen where the PSG expects numbers to be entered by the user. At this point you must enter a number (s), as it will not allow you to move back additional menus. You can however, reset the unit to the first menu by holding the RESET/STOP key for 2 seconds.

The ENTER/START key is used to select the currently displayed choice or to start a pulse. It is also used to switch between outputs when in Min/Max mode while generating a duty Cycle pulse, or in Current or Voltage output.

The STOP/RESET key is used to stop the current output, allowing you to change its value, or rearrange wires. To select another output or range, press and hold this key for 2 seconds and the program will reset back to the first menu. All settings will be lost on reset.

UNIT AND RANGE DESCRIPTIONS:

Connect White (+) and Black (-) leads to 24 Volt AC or DC power supply. Turn the ON/OFF switch located on right side of PSG to ON (forward).

The unit and format of the values entered into the PSG based on the type of output desired. Here are ranges for each style of output:

One Shot and **Looped** pulses: Pulse times range from 0.001 – 999.99 (S, M or H).

Duty Cycle Period Time: Valid values can range from 0.001 – 999.999 (Seconds only)

Duty Cycle: Values are entered in percent ranging from 0-100% in 1% increments. This percentage value is the percent of the Period time that the pulse will be turned on.

Analog mode offers Voltage spans from 0-10.00 volts and Current spans from 0 – 20.00mA. Each of these analog outputs have 255 steps of resolution.

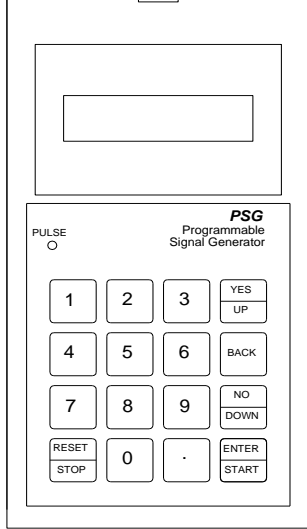
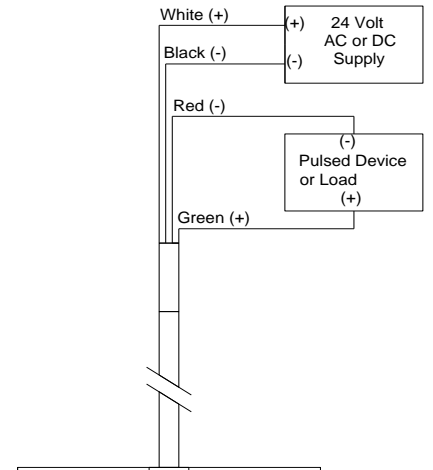
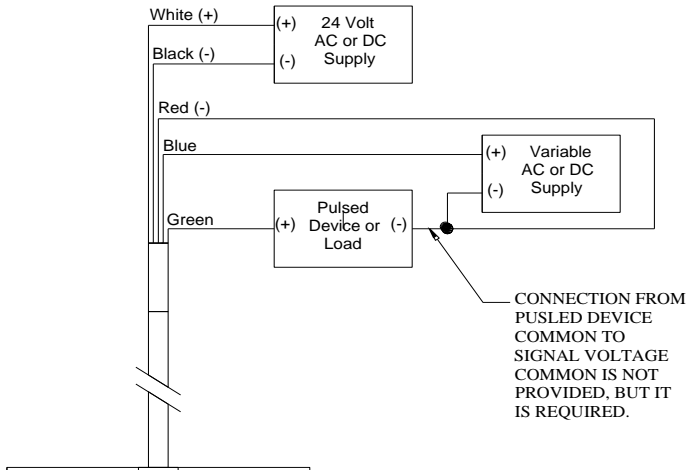

Dry Pulse Output Setup

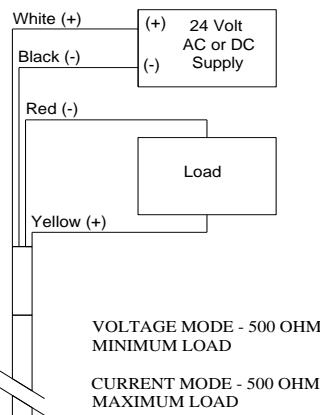

Analog Output Setup

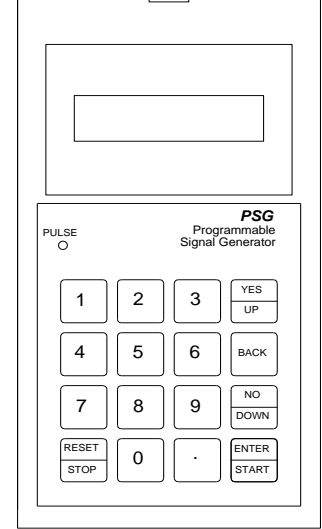

Wet Pulse Output Setup

NOTE:
 Select mode before making PSG signal wire connections.
 Remove signal clips when resetting from current to voltage or voltage to current.

FUSE
 Internal, 5 x 20mm, 250V, Fast Acting
 ACI # FS017 - 1ea. 0.1 Amps, 250V, FA (LittleFuse 235.100 or Bussman GMA-100MA)
 ACI #FS018 - 1ea. 0.025 Amps, 250V, FA (LittleFuse 235.250 or Bussman GMA-250MA)

ENTERING VALUES/STARTING THE OUTPUT:

When the cursor is on the first or middle column of the display, the PSG is ready for a number to be entered. The first character of the number is positioned one column to the right of the cursor.

Set the value using the number keys and the decimal point (the decimal point is not used when entering a Duty Cycle percentage) and press ENTER/START to register your selection. The BACK key will correct mistakes at this point.

One Shot pulse:

1. Type in the value on the keypad for a One Shot pulse.
2. Press the ENTER/START key to register the value and the cursor advances to a letter indicating a Time Unit be selected.
3. Use the NO/DOWN key to select a time unit; (Seconds, Minutes or Hours), and...
4. Press ENTER/START to accept the unit. The PSG will then ask if there are more pulses. If no, then the PSG will allow the user to enter the pulse number that they wish to output. If yes, then the PSG will allow the user to enter up to 3 more pulse times.

Looped pulse:

1. Type in the ON time for Looped pulse.
2. Press the ENTER/START key to register the value and the cursor advances to the letter Indicating the Time Unit be selected.
3. Type in the OFF time.
4. Press the ENTER/START key to register the value and the cursor advances to a letter indicating the Time Unit be selected.
5. Use the NO/DOWN key to select which time unit you want; (Seconds, Minutes or Hours), and...
6. Press ENTER/START to accept the unit.

Duty Cycle: Mode selections are slightly different in sequence.

1. Select Duty Cycle mode, then...
2. Enter the Time Period in seconds (the only Time Unit choice for this mode).
3. Press the ENTER/START key to store the value and advance the PSG to the next screen where you
4. Enter the Duty Cycle value(s) in percent (the only unit choice), and
5. Register the percent by pressing ENTER/START.

Analog:

1. Select Voltage or Current.
2. Press ENTER/START to accept selection and PSG advances to the next screen.
3. Select Min/Max or Absolute
4. Press ENTER/Start to accept the selection.
5. Type in the output value (minimum value in the case of Min/Max)
6. Accept by pressing the ENTER/START key. If you are entering values for Min/Max the cursor then moves to the right for the Max value.
7. Enter the maximum value and...
8. Press ENTER/START to accept the selection.

Note: When dual values modes are used, (i.e. Looped pulses, Min/Max Duty cycle or Min/Max Analog outputs), make sure you have selected and entered the second value or the output will not start. If two values are being used, only one is valid at a time. Use the ENTER key to toggle between the two, and select which one is valid.

RAMPING THE OUTPUT:

Analog Voltage and Current, and Duty Cycle output values can be ramped up or down. Pressing the Up or Down keys while the output is being generated will increment and decrement the output value. As the value on screen changes, the output will respond immediately. Use the ENTER key to select which value will be changed, before using the UP/DOWN keys. This, of course, only applies when two values are being used.

WARNINGS AND LIMITATIONS MESSAGES

Since several different electrical styles can be sent on the same wire, which can cause electrical conflicts that can harm the PSG and/or the devices attached to it, there is a 'Check Setup' warning once the output have been selected.

When selecting the duty cycle period, the value must be greater than 0.010S. If the value is below 0.010S, the period is automatically set to 0.010S and a warning is displayed. If period entered is less than 0.100S, a warning message will be displayed informing the user that the pulse may not occur at every duty cycle.

No warnings are given for a 0 value entry of a pulse as the PSG can handle this value. There is no warning when an analog value is set above the maximum value. The PSG will set the value entered to the maximum value.