

Multiple DDC Signal Input to Proportional Resistance Output

DRN4 WIRE TERMINATION ASSEMBLY GUIDE

COLOR	CONNECTION	Wire Termination is
White	Motor W (min)	Female Spade
Blue	Motor B (max)	Female Spade
Red	Motor R (wiper)	Female Spade
Black	Motor T2	Female Spade
Orange	Motor T1	Female Spade
Black	24 VAC (-)	Male Spade
Orange	24 VAC (+)	Male Spade
Yellow	Floating Point Up/Analog/Pulse	Flying Leads
Green	Signal Common	Flying Leads
Gray	Floating Point Down	Flying Leads

SWITCH SETTINGS

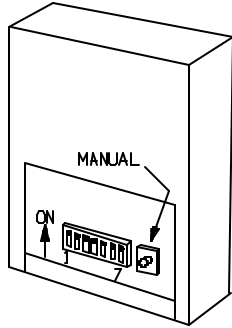
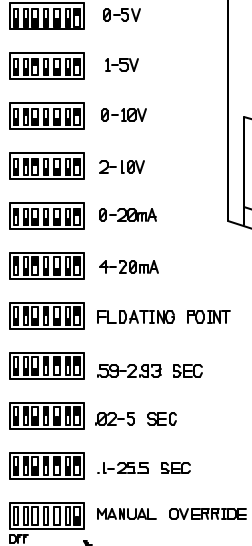

Use Caution when replacing access panel on DRN4. Excess pressure could change switch settings when you slide it closed.

← **These switches** are shown switched up in the **ON** position

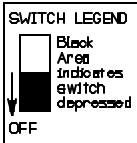
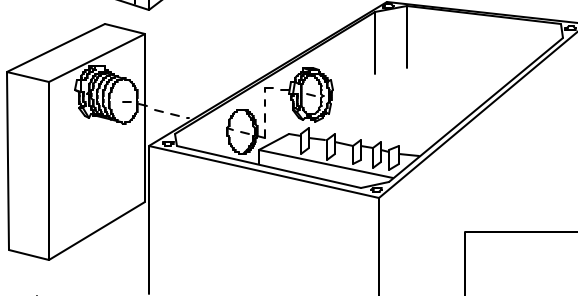

Analog Input to DRN4

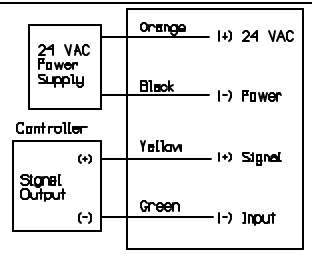

Floating Point to DRN4

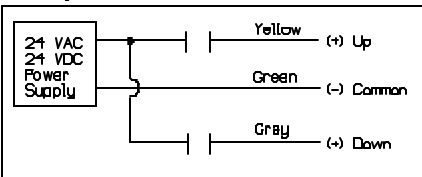

Pulse to DRN4

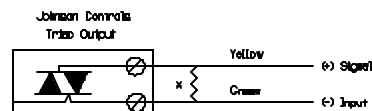
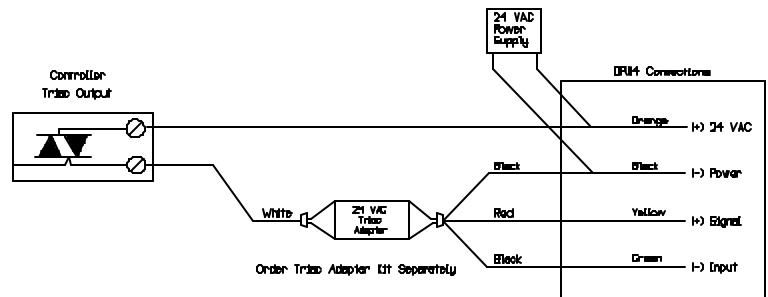
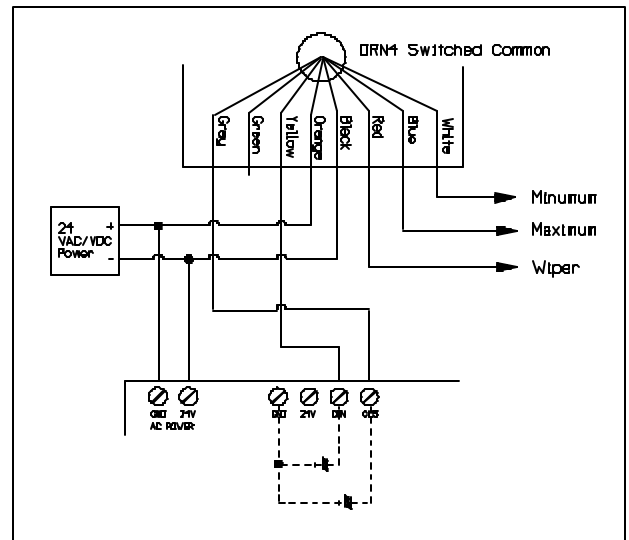
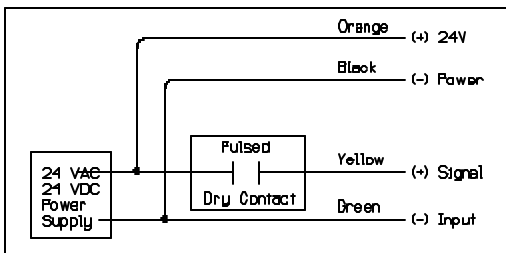

* 1K Ohm Resistor, 2 ea. included with DRN4

INSTALLATION

READ THESE INSTRUCTIONS BEFORE YOU BEGIN INSTALLATION

Tools needed may include a Phillips screwdriver to remove actuator cover screws, 3 wire nuts for two signal and one common wire connections and a voltmeter for troubleshooting if necessary.

Turn off power to the actuator and remove the actuator cover. Remove a knock-out on the actuator near the actuator control terminals. Open the access cover on the DRN4 and set the switches to the desired mode of operation. Replace the switch access cover on the DRN4 and remove the outermost lock-nut from the DRN4 box connector fitting. Feed the DRN4 wires through the actuator knock-out and the lock-nut. Tighten the lock-nut onto the DRN4 fitting. Connect the DRN4 leads with spade connectors to the correct actuator terminals, the external control source and the power source. Wire nut any unused wire and replace the actuator cover.

POWER CONNECTIONS

Be sure to follow all local and electrical codes. Refer to wiring diagram for connection information.

- 1) If required by BAS or controller specification, the 24 volt AC neutral can be earth grounded at the transformer. Analog input, digital input, and analog output circuits should not be earth grounded at two points. Any field device connected to this transformer must use the same common. If you are not sure of other field device configuration, use separate transformers for isolation.
- 2) If the 24 volt AC power is shared with other devices that have coils such as relays, solenoids, or other inductors, each coil must have an MOV, Transorb, or other spike snubbing device across each of the shared coils. Without these snubbers, coils produce very large voltage spikes when de-energizing that can cause malfunction or destruction of electronic circuits.

CHECKOUT

After DIP switches for the signal input compatible with the external controller are set, power the actuator and have the external controller send a minimum signal and then a maximum command signal to verify proper actuator positioning. The LED under the cover will indicate according to the following:

MANUAL OPERATION WITH OVERRIDE BUTTON:

Manual operation is allowed by placing dip switch (7) in the "OFF" position. Pressing override button allows you to manually simulate the input range selected by the DIP switches (analog, pulse or tri-state).

ANALOG:

Output ramps up while button is pressed (LED is off at 10VDC (maximum signal), when released the output will begin ramping down to zero (LED is on at 0VDC (minimum signal). Between minimum and maximum, the higher the input voltage, the shorter the LED pulse.

PULSE:

Pressing override button simulates signal within the pulse range selected. LED flashes only when PWM signal is being received.

FLOATING POINT:

Output will ramp up while button is pressed (55 seconds for a full scale) and remain at point of release. LED remains lit all the time. Remove power to DRN4 to reset to zero.

TRIAC INPUT

When using a triac input signal from an external controller, a **Triac Adapter Kit must be ordered with the DRN4**. Connect the black common (-) wire from the power source, and the black common wire on the triac adapter to the incoming power lead.

Suggestion: Clip off a short section of the power wire to include the female connector. Clip off the male spade connector on the DRN4 black lead, then wire nut triac adapter lead, DRN4 lead, and the power wire with the female connector together. Plug into motor. Wire nut the triac adapter red wire and the DRN4 yellow wire together, the other triac adapter black wire and the DRN4 green wire together.

Johnson Control Triac input signals require only the installation of a 1K ohm 1/2 watt resistor. The resistor is added across the DRN4 signal input wires (yellow and green), and wire nut to the external controller signal leads. An added precaution would be to wrap resistor with electrical tape.

EU Commission Directive 2002/95/EC (RoHS) Compliant

Power Supply:	24 VAC	Power Consumption:	130 mA
Input Impedance:	Voltage/100,000 ohms	Output Resolution:	32 steps
	Current/250 ohms	Output Range:	0 to 135 ohms - 3 watts