

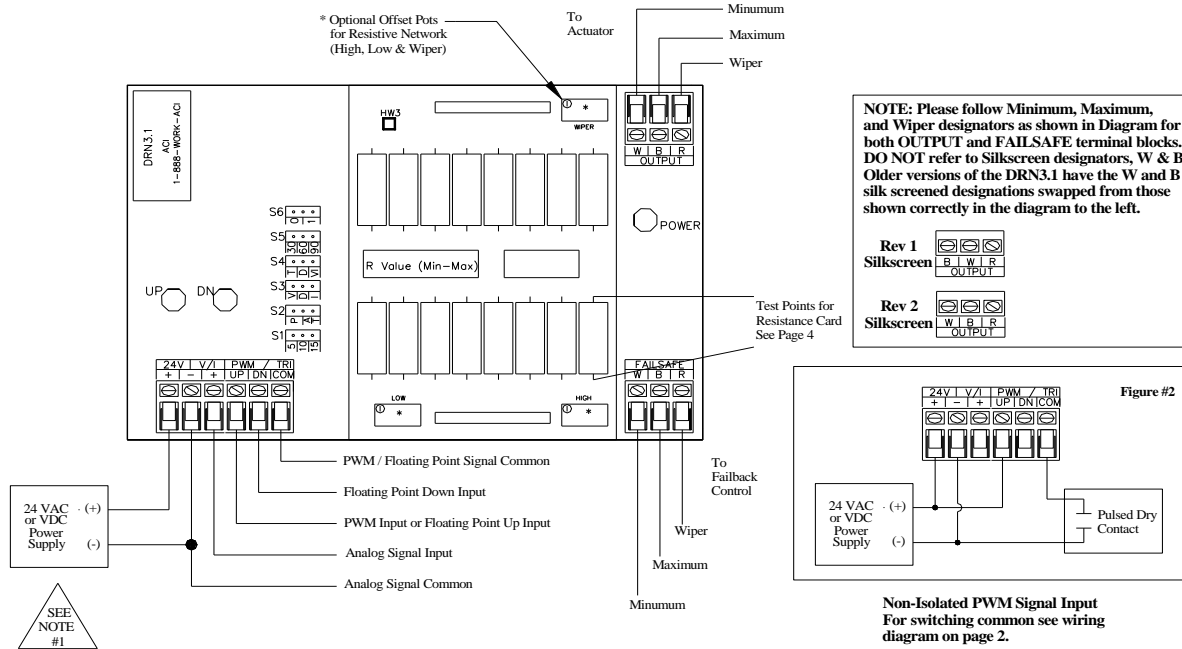

Installation and Operation Instructions DRN3.1

Pulse / Analog / Floating Point to Proportional Resistance Output



JUMPER SETTINGS - ANALOG

Uses same Version #1 or #2 chips as Pulse & Floating Point programs

Input	S1	S2	S3	S4	S5	S6
0 - 5 Volts						
0 - 10 Volts						
0 - 15 Volts						
1 - 5 Volts						
2 - 10 Volts						
3 - 15 Volts						
0 - 20 mA						
4 - 20 mA						

JUMPER SETTINGS - PULSE & FLOATING POINT

Version #1 - Chip # 0052y0h.hex

Input	S1	S2	S3	S4	S5	S6
0.1 - 25.5 sec. pulse						
0.02 - 5 sec. pulse						
0.59 - 2.93 sec. pulse						
30 sec. Floating Pt.						
60 sec. Floating Pt.						
90 sec. Floating Pt.						

JUMPER SETTINGS - PULSE & FLOATING POINT

Version #2 - Chip # 0054y0b.hex

Input	S1	S2	S3	S4	S5	S6
0.1 - 10 sec. pulse						
0.023 - 6 sec. pulse						
45 sec. Floating Pt.						
120 sec. Floating Pt.						
240 sec. Floating Pt.						

JUMPER SETTINGS - DUTY CYCLE PULSE

Version #4 - Chip # 0305y1a.hex

Input	S1	S2	S3	S4	S5	S6
0.1 - 10 sec. pulse						

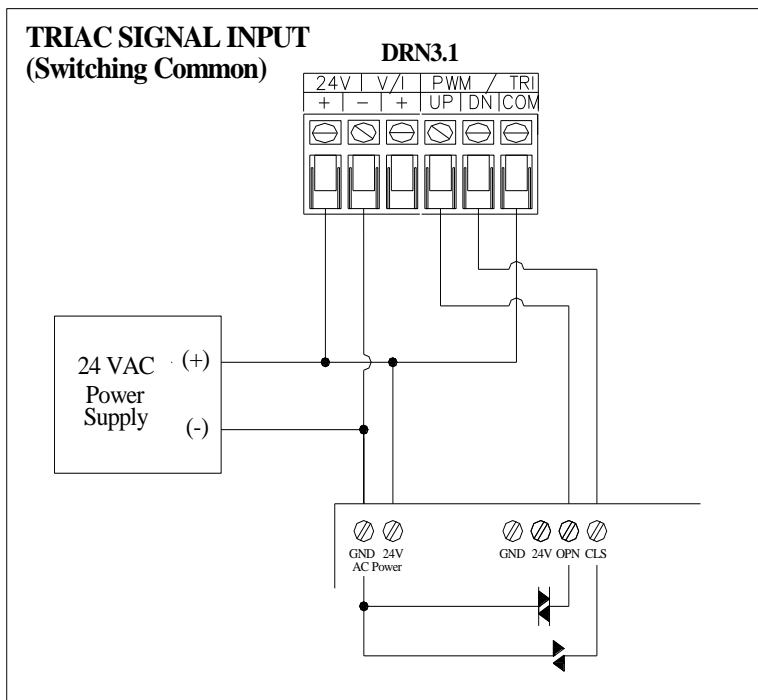

INSTALLATION

READ THESE INSTRUCTIONS BEFORE YOU BEGIN INSTALLATION.

Ground yourself before touching board. Some components are static sensitive.

MOUNTING:

Circuit board may be mounted in any position. If circuit board slides out of snap track, a non-conductive "stop" may be required. Use only fingers to remove board from snap track. Slide out of snap track or push against side of snap track and lift that side of the circuit board to remove. Do not flex board or use tools.

POWER CONNECTIONS – THIS PRODUCT ACCEPTS 24 VDC or 24 VAC POWER.

Be sure to follow all local and electrical codes. Refer to wiring diagram for connection information.

Be sure to make all connections with the power off.

1. DC Power – Refer to wiring diagram for connection information.
If the 24 VDC power is shared with devices that have coils such as relays, solenoids, or other inductors, each coil must have an MOV, DC Transorb, or diode placed across the coil or inductor. The cathode, or banded side of the DC Transorb or diode, connects to the positive side of the power supply.
2. AC Power – Refer to wiring diagram for connection information.
Check the wiring configuration of any other loads that may be connected to this transformer. If required by BAS or controller specification, the 24 VAC neutral can be earth grounded at the transformer. Analog input, digital input, and analog output circuits should not be earth grounded at two points. Any field device connected to this transformer must use the same common. If you are not sure of other field device configuration, use separate transformers for isolation.

If the 24 volt AC power is shared with other devices that have coils such as relays, solenoids, or other inductors, each coil must have an MOV, AC Transorb, or other spike snubbing device across each of the shared coils. Without these snubbers, coils produce very large voltage spikes when de-energizing that can cause malfunction or destruction of electronic circuits. Refer to wiring diagram for connection information.
3. You should measure the actual voltage output of the secondary. If the output is not fully loaded you may read a higher voltage than the circuit board can handle.



CHECKOUT

Version identification: Most DRN3.1's are shipped as version #1. An IC chip on the DRN3.1 is labeled with the version program number. Make sure you have the correct version. You may have to remove the resistor network card to view and [compare to table on page 1](#).

Resistor network: Each DRN3.1 requires a plug-in [resistor network card](#) (RN) to operate properly. This resistance card determines the simulated slide wire potentiometer values for the output. Insert the RN (usually in a separate package from DRN3.1) into the DRN3.1. There are two rows of pins on the RN and two rows of female connections on the DRN3.1. See page 1 drawing for proper RN orientation.

The DRN3.1 resistance output simulates a potentiometer. The Terminal Block located on the far right is the Wiper. The Terminal Block located in the middle is the Maximum; the high end of the potentiometer. The Terminal Block located on the far left is the Minimum; the low end of the potentiometer. Upon power-up, the wiper will start at the Minimum position and will remain there until the first PULSE or FLOATING POINT signal is received. The ANALOG version will begin tracking the input signal instantly after "sampling" the input signal to eliminate error. The output resistance will not change on the PULSE version until the end of the pulse. To check the resistance output, vary the input signal and measure the resistance. The resistance between terminals Wiper and Minimum will increase as the input signal increases and the resistance between Wiper and Maximum will decrease. If both floating point inputs are on for 3 seconds, the DRN3.1 resets to minimum resistance output.

Setting the jumpers: Remove power from the DRN3.1. Place jumpers S1 through S6 in the appropriate positions. All six jumpers must be in proper position for each input type. Hold the DRN3.1 vertical with the label at top right to orient its jumper shunts with the chart. Version #1 and Version #2 share the same analog inputs. Ramping time for floating point inputs are selectable. Version #4 accepts a continuous pulse signal command string within a 10 second window. No pulse in this 10 second window produces minimum percent output. A ten second pulse in this 10 second window produces 100% output. Continuous pulse will produce maximum percent output.

When power is restored, changes will be recognized. Apply 24 VAC/VDC to "PWR" terminal, confirm power light is on and measure voltage to confirm proper voltage.

When power is applied to terminals "+24V" and "-", the POWER LED will light and the Fail Safe terminals will be disconnected from the output terminals. Fail-back only occurs when the DRN3.1 has lost power. When the DRN3.1 is not powered on terminals "24V" and "-", the Fail Safe terminals are connected to the Output terminals. Check for continuity.

The DRN3.1 will automatically fail-back to 0 Ohms. For a fail-back to some other resistance, a manual potentiometer or fixed resistor can be added between Minimum and Wiper only, if out putting a normal acting signal. If out putting a reverse acting signal, please contact ACI for assistance.

TESTING THE INPUT:

Voltage input: Connect the "+" or positive wire to "V/I+". Connect the common to "24V-". Apply a voltage from control source. Measure voltage at "24V-" and "V/I+" at terminal block.

If the commanded voltage is not present, remove the "+" or positive wire and measure from "+" wire to "24V-". If no voltage is measured check the wiring from controller. If voltage disappears or is reduced when connected to the DRN3.1, confirm input jumper is set to voltage mode and remove signal input wires and power from unit. Measure the resistance from "24V-" to "V/I+". Resistance in the voltage modes will be around 10K. If input is shorted, contact ACI Technical Support. If not shorted, remove the controller input common and connect 24 VDC/VAC to the DRN3.1. Check for ground loop: Place meter in voltage mode and measure VAC and VDC from analog input common wire to power supply common. If any voltage is measured in DC or AC a ground loop most likely exists. Check power commons and / or ground potentials. Use a separate 24 volt transformer for the DRN3.1 and let common float.

Current input: Confirm the input jumper is in the correct position. Measured input resistance should be around 250 Ohms. Connect "+" or positive to "V/I+" and common or "-" to "24V-". Apply mA signal. Place meter in voltage and measure voltage across "V/I+" and "24V-" 4 mA is equal to 1 volt and 20 mA is equal to 5 volts. Use Ohms Law to find voltage from current. (Current x 250 = Volts. Sample: 12 mA or 0.012 x 250 = 3 volts). If no voltage is present, check wiring for open. Current cannot exist without voltage present from "V/I+" to "24V-" unless dead shorted.

Pulse Width Modulated (or PWM) input: Apply 24 VAC/VDC to the PWR terminals. Connect your meter to the Wiper and Maximum terminals on the output terminal block. Set meter to resistance range of resistor network. Connect a jumper wire from UP to the 24V "+" terminal (this is your jumper wire #1). Connect another jumper wire into the 24V "-" terminal only (this is your jumper wire #2). You are now ready to simulate a timed pulse signal. For testing purposes, select 0.1 to 25.5 or 0.1 to 10 seconds on version 2. Be sure to reset power to allow the DRN3.1 to recognize new settings. Take the free end of jumper wire #2 and connect by holding wire to the COM terminal. Reference Figure #2. Count to 50% of timing range and remove. Verify the pulse UP LED indication. Voltage can be measured across the input to verify proper voltages. Read the output. Has the output changed? The output should be close to 50% of set output. If no, contact ACI Technical Support. If yes, unit is functioning properly.

Floating Point / Tri-state: Apply 24 VAC/VDC to the PWR terminals. Connect your meter to the Wiper and Minimum terminals on the output terminal block. Set meter to resistance range of resistor network. Connect a jumper wire from UP to the 24V "+" terminal (this is your jumper wire #1). Connect a jumper wire to the 24V "-" only (this is your jumper wire #2). You are now ready to simulate a timed Up signal. For testing purposes, select the 30 or 45 second range on version 2. Be sure to reset power to allow the DRN3.1 to recognize new settings. Take the free end of jumper wire #2 and connect by holding wire to the Com terminal. Count to 50% of timing range and remove. Verify the pulse UP LED indication. Voltage can be measured across the input to verify proper voltages. Read the output. Has the output changed? The output should be close to 50% of the set output. Moving jumper wire #1 from UP to DOWN, and repeating the same test, should decrease the output signal. If no, contact ACI Technical Support. If yes, unit is functioning properly.

Testing the output:

Measured resistance from Wiper to Minimum terminal blocks will begin at the minimum signal, as specified by your resistor network, and will increase proportionally to the commanded input value. To reverse the output signal, measure resistance from Wiper to Maximum terminal blocks. This will begin at the maximum signal, as specified by your resistor network, and will decrease proportionally to the commanded input value. A clicking sound will occur when resistance is changed. Resistance changes in steps and is divided into 256 equal steps. Exception is version 3 where step size is selected.

Command a change or simulate an input signal to change the output. Measure the resistance value. If the resistance has not changed, check settings and reset power.

Verify the input is functional.

If yes, then contact ACI Technical Support.

Most common problem:

The analog input from the controller can contain electrical noise. This noise is seen by the DRN3.1 as a change in commanded input signal and quickly changes the output. The most common symptom is a constant chatter of the relays. Standard precautions should be taken to prevent noise on the signal input of the DRN3.1 (i.e.: Do not run signal wiring near line voltage wiring or florescent light fixtures). Versions 1 and 2 of the DRN3.1 were modified in 2001 to add extra filtering to the input. Time response full scale is about 6 seconds. Check version number on your DRN3.1. If high speed response or extra filtered versions is required contact ACI Sales Department.

AVAILABLE STANDARD RESISTOR NETWORKS

RN – 0/135 – 3 watts (± 5%)	RN – 0/1500 – 1/4 watt (± 5%)	RN – 0/5K – 1/4 watt (± 5%)
RN – 0/270 – 3 watts (± 5%)	RN – 0/2K – 1/4 watt (± 5%)	RN – 0/10K – 1/4 watt (± 5%)
RN – 0/500 – 1/4 watts (± 5%)	RN – 0/3K – 1/4 watt (± 5%)	RN – 0/20K – 1/4 watt (± 5%)
RN – 0/1000 – 1/4 watts (± 5%)	RN – 0/4K – 1/4 watt (± 5%)	RN – 0/40K – 1/4 watt (± 5%)

Other Ranges, Inputs, and Wattages are available by custom order.

*TEST POINTS FOR RESISTOR NETWORK (RN) CARD (See Drawing, page 1)

The Resistor Network card does not have to be attached to the DRN3.1 motherboard for this test, but if attached to the DRN3.1, you must remove power before testing. Using an OHM meter, test the last resistor as illustrated on page 1. The value indicated should be ½ the total resistance range of the Resistor Network card.

Example: A 500 Ohm reading indicates a 0 to 1000 Ohm Resistor Network card.

A 750 Ohm reading indicates a 0 to 1500 Ohm Resistor Network card.

EU Commission Directive 2002/95/EC (RoHS) Compliant

Power Supply Voltage: 24 VAC ±10% 24 VDC +25%/-8%	Power Consumption: 250 mA
Digital Inputs: 10 to 26.4 VAC or 4.5 to 30 VDC	Digital Input Impedance: 750 Ohms nominal
Resolution: 256 steps	Analog Input Impedance: Voltage/10,000 Ohms Current/250 Ohms