



Installation and Operation Instructions

Part # A/CR-DC-5A, A/CR-DC-12A, A/CR-12DC-12A,
A/CR-24AC-10A, A/CR-115AC-8A, A/CR-230AC-8A

Please Read Instructions Carefully Before Installation!

■ Safety

- ⚠ This product is not intended to be used for Life or Safety applications.
- ⚠ This product is not intended for use in any hazardous or classified locations.
- ⚡ Disconnect and lock out all power sources before installation as severe injury or death may result from electrical shock due to contact with high voltage wires.

■ Installation

Make sure that all installations are in compliance with all national and local electrical codes. Only qualified individuals that are familiar with codes, standards, and proper safety procedures for high-voltage installations should attempt installation. The Command Relays require an external power source for the relay coils (See Table #1).

ACI Model #	Coil Voltage	Rated Current @ 60Hz	Rated Current @ 50Hz
A/CR-DC-5A	23 to 31.2VDC	17mA @ 24VDC	-
A/CR-DC-12A	20 to 31.2VDC	17mA @ 24VDC	-
A/CR-12DC-12A	10 to 15.6VDC	33.33mA @ 12VDC	-
A/CR-24AC-10A	16 to 26.4VAC	28.30mA @ 24VAC	31.30mA @ 24VAC
A/CR-115AC-8A	80 to 132VAC	5.35mA @ 115VAC	5.85mA @ 115VAC
A/CR-230AC-8A	165 to 264VAC	2.76mA @ 230VAC	3.00mA @ 230VAC

Table #1



Warning: Never rely on the Red LED to determine whether power is present at the command relay. The Red LED will indicate whether the relay coil is energized (LED On) or De-energized (LED OFF).

The Command Relays may be mounted in any position using the (2) #8 x 3/4" Tek screws and the mounting holes in the base or snapped directly on to the 35mm DIN rail (See Figures 1 & 2). The ACI current switches and sensors may be snapped directly on to the top of the command relays (See Figure 3) or multiple command relays may be snapped directly on to the top of each other as shown in Figure 4. Leave a minimum distance of 1" (3 cm) between the command relays and any other magnetic devices such as contactors and transformers.

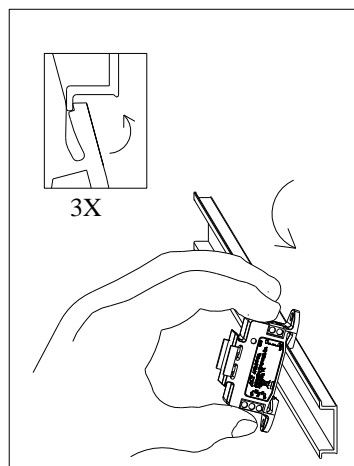

Figure 1: Relay Placed on Rail

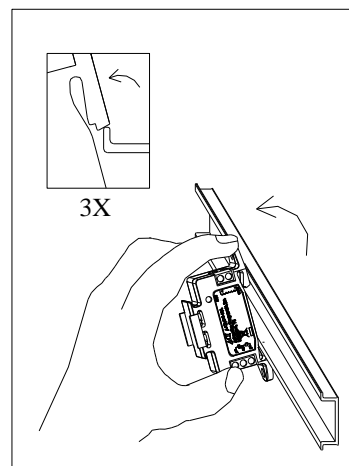

Figure 2: Relay Removed from Rail

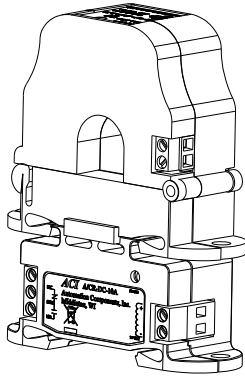

Figure 3:

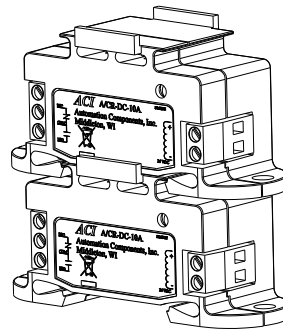

Figure 4:

■ Wiring

ACI recommends the use of a 14 to 24 AWG wires, **copper wire only** for all command relay coil installations. The command relay DC coil terminals are polarity sensitive. ACI recommends the use of 12 to 14 AWG wires, **copper wire only** for all command relay contacts (Output) installations. The maximum tightening torque to be used on the terminal block connections is 0.6 Nm or 5.3 in-lbs.

■ Operating Specifications

ACI Model #	Contact Rating	Max. Switching Voltage	Max. Switching Current
A/CR-DC-5A	5A @ 250VAC General Use 5A @ 125VAC Resistive 5A @ 30VDC Resistive 1/4HP, 120/250/277VAC C150 Pilot Duty	250VAC, 30VDC	5 A (NO)/3 A (NC)
A/CR-DC-12A	12A @ 250VAC General Use 12A @ 250VAC Resistive 12A @ 30VDC Resistive 1HP, 120/240/480VAC – NO 1/2HP, 120/240/480VAC – NC A300 Pilot Duty	250VAC, 30VDC	12 Amps
A/CR-12DC-12A	12A @ 250VAC General Use 12A @ 250VAC Resistive 12A @ 30VDC Resistive 1HP, 120/240/480VAC – NO 1/2HP, 120/240/480VAC – NC A300 Pilot Duty	250VAC, 30VDC	12 Amps
A/CR-24AC-10A	10A @ 250VAC General Use 10A @ 250VAC Resistive 10A @ 30VDC Resistive 1HP, 120/240/480VAC – NO 1/2HP, 120/240/480VAC – NC A300 Pilot Duty	250VAC, 30VDC	10 Amps
A/CR-115AC-8A	8A @ 250VAC General Use 8A @ 250VAC Resistive 8A @ 30VDC Resistive 1HP, 120/240/480VAC – NO 1/2HP, 120/240/480VAC – NC A300 Pilot Duty	250VAC, 30VDC	8 Amps
A/CR-230AC-8A	8A @ 250VAC General Use 8A @ 250VAC Resistive 8A @ 30VDC Resistive 1HP, 120/240/480VAC – NO 1/2HP, 120/240/480VAC – NC A300 Pilot Duty	250VAC, 30VDC	8 Amps

Wiring Example

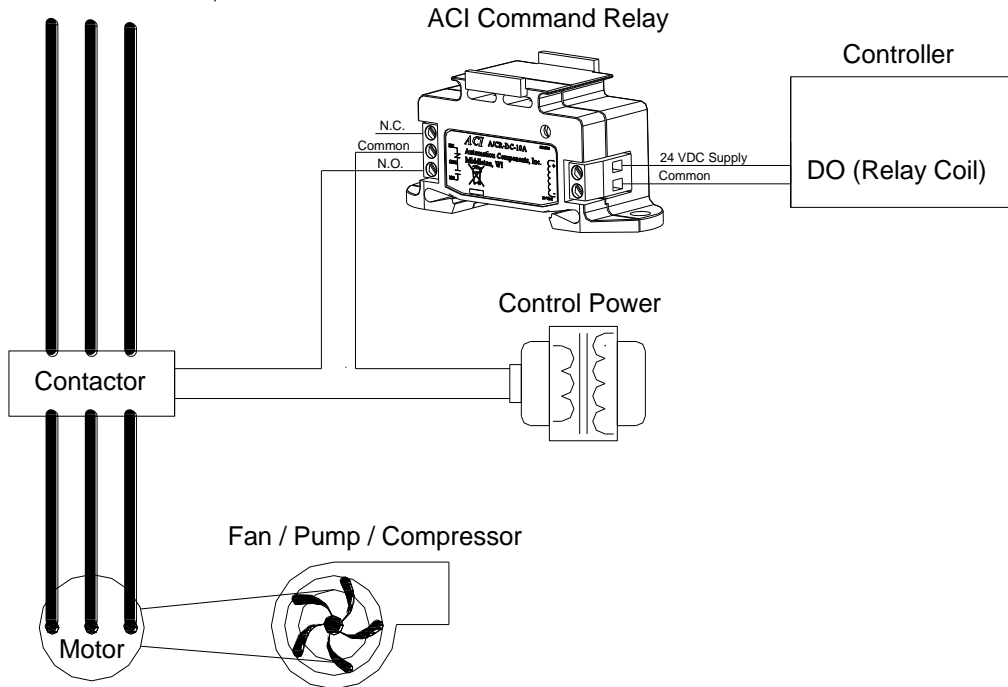

Wiring Example

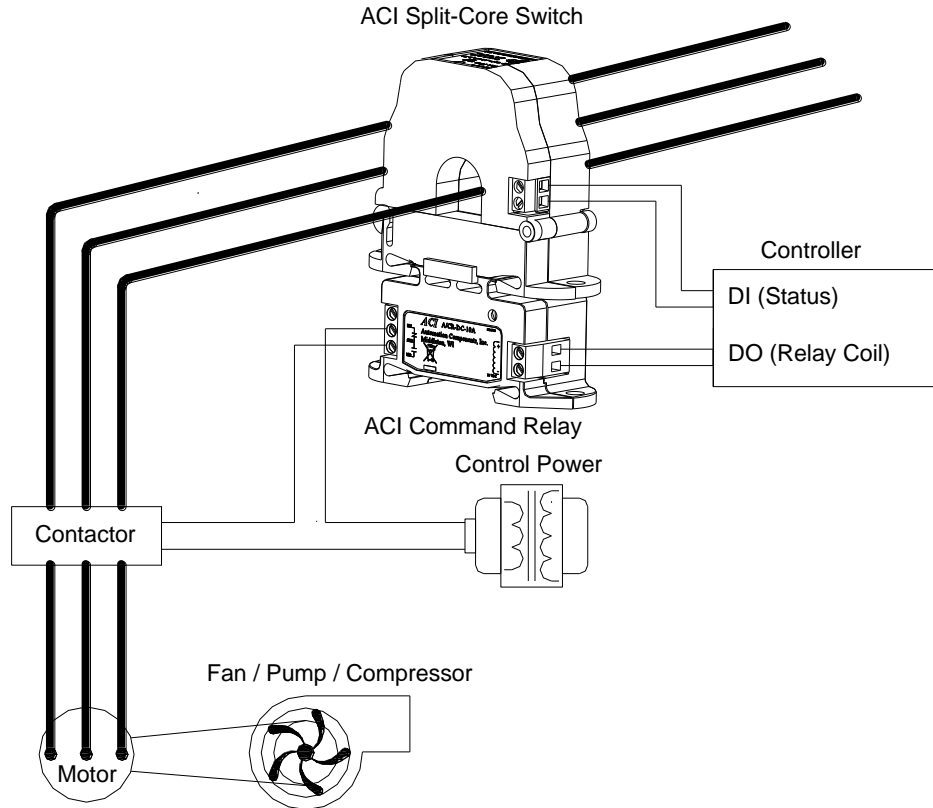

■ Troubleshooting

Problem	Solution
LED is on but the Command Relay didn't activate	Disconnect the wires from the command relay output. Measure the resistance across the contacts with an Ohmmeter.
LED didn't turn on and the Command Relay didn't activate	Verify the voltage at the coil input See Table #1 on Page 1.
LED not on but the Command Relay is Activated	Disconnect the wires from the command relay output. Measure the resistance across the contacts with an Ohmmeter. LED not indicating correctly, may have been damaged

■ WEEE Directive

At the end of their useful life the packaging and product should be disposed of via a suitable recycling centre. Do not dispose of with household waste. Do not burn.

