

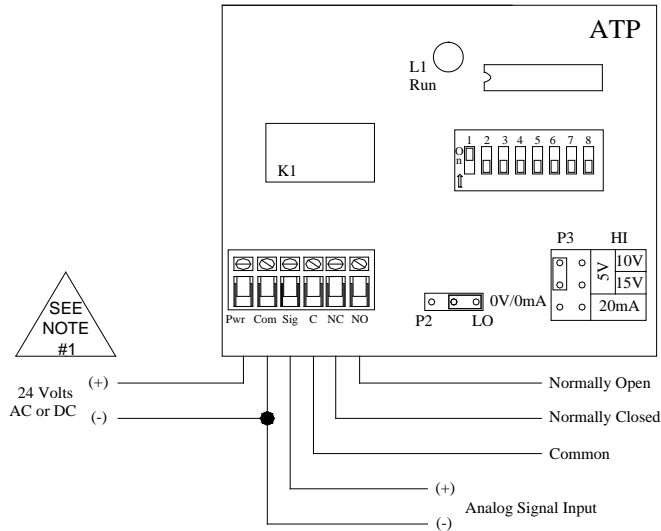

# Installation and Operation Instructions ATP-R

## Analog Input to Relay Pulse Output



Analog Input	P2 (Offset)	P3 (Maximum)
0 - 5V		
0 - 10V		
0 - 15V		
0 - 20mA		
1 - 5V		
2 - 10V		
3 - 15V		
4 - 20mA		

## INSTALLATION

### READ THESE INSTRUCTIONS BEFORE YOU BEGIN INSTALLATION.

Ground yourself before touching any electronic equipment. Some components are static sensitive.

#### Mounting:

The interface device may be mounted in any position. If circuit board slides out of snap track, a non-conductive "stop" may be required. Use only fingers to remove board from snap track. Slide out of snap track or push against side of snap track and lift that side of the circuit board to remove. Do not flex board or use tools.



#### POWER CONNECTIONS – THIS PRODUCT ACCEPTS 24 VDC OR 24 VAC POWER.

Be sure to follow all local electrical codes. Refer to wiring diagram for connection information. Make all connections with the power off.

- 1.) The secondary supply voltage to the interface should be between 22 and 28 volts AC or DC and isolated from earth ground, chassis ground, and neutral leg of the primary winding. If required by BAS or controller specification, the 24 VAC neutral can be earth grounded at the transformer. Analog input, digital input, and analog output circuits should not be earth grounded at two points. Any field device connected to this transformer must use the same common. If you are not sure of other field device configuration, use separate transformers for isolation.
- 2.) If the 24 volt AC or DC power is shared with other devices that have coils such as relays, solenoids, or other inductors, each coil must have an MOV (if AC), a diode (if DC), AC or DC transorb, or other spike snubbing device across each of the shared coils. Without these snubbers, coils produce very large voltage spikes when de-energizing that can cause malfunction or destruction of electronic circuits.
- 3.) You should measure the actual voltage output of the secondary. If the output is not fully loaded you may read a higher voltage than the circuit board can handle.

**ATP Pulse Timing:**

The ATP converts an analog signal into a digital pulse output signal. The range of the analog input signal is selectable by the positions of the jumper shunts P2 and P3 (see diagram above).

Pulse timing consists of an "ON" pulse and an "OFF" interval. "OFF" interval is 1 second on standard and custom ranges.

The standard ranges for Version 1 or 2 are selected by dip switch 1 "ON" and proper settings of switches 2 and 3, allows for four different output timing ranges. Switches 4 through 8 are not active when switch 1 is on. Version 2 operates the same as Version 1 except when the input falls at or below 10% of the input signal range, no pulse output occurs, allowing for "OFF" setting of electric heat Solid State Relays (SSR's).

Input Signal									Standard Output Range			
0-5V	1-5V	0-10V	2-10V	0-15V	3-15V	0-20mA	4-20mA	Steps	Dip:1,3 20ms/Step ON	Dip:1 23ms/Step ON	Dip:1,2 100ms/Step ON	Dip:1,2,3 9ms/Step ON
0	1	0	2	0	3	0	4	0	0	0	0.1	0.59
1.25	2	2.5	4	3.75	6	5	8	64	1.3	1.5	6.5	1.18
2.5	3	5	6	7.5	9	10	12	128	2.5	3	12.8	1.76
3.75	4	7.5	8	11.25	12	15	16	191	3.8	4.5	19.2	2.35
5	5	10	10	15	15	20	20	255	5	6	25.5	2.93
No pulse is output when Version 2 input falls at or below 10% of the input signal range.								A/D converter	Johnson	Solidyne	Andover	Novar

The custom mode (refer to chart below) allows for 128 pulse timing ranges. The custom mode, selected by dip switch 1 "OFF", allows switches 2 through 8 to select "ON" pulse timing ranges. These "ON" times are cumulative and multiple switches can be selected.

Example: 0-10V signal input to an output pulse range of 150 milliseconds (ms) to 38.4 seconds.

- To obtain a starting pulse signal of 150ms, turn switches 2 & 3 ON, all others OFF (dipswitch 2 on = 50ms at 0 volts, and dipswitch 3 on = 100ms at 0 volts).
- By looking at the bottom chart note that at 10 volts input signal, the values for switches 2 & 3 "ON" are 12.8 and 25.6 seconds respectively, totaling 38.4 seconds.

The output range selected is now 150ms to 38.4 seconds.

All times on the charts are shown in seconds (or portion of) with a maximum 6.4 seconds. A pulsing "RUN" LED on the ATP indicates a pulse width signal output.

Input Signal									Custom Output Range (DIP Switch Values if ON)							
0-5V	1-5V	0-10V	2-10V	0-15V	3-15V	0-20mA	4-20mA	Steps	Dip:2 50ms/Step ON	Dip:3 100ms/Step ON	Dip:4 200ms/Step ON	Dip:5 400ms/Step ON	Dip:6 800ms/Step ON	Dip:7 1.6s/Step ON	Dip:8 3.2s/Step ON	Dip:2-8 6.35s/Step ON
0	1	0	2	0	3	0	4	0	0.05	0.1	0.2	0.4	0.8	1.6	3.2	6.4
1.25	2	2.5	4	3.75	6	5	8	64	3.3	6.5	13	26	52	104	208	413
2.5	3	5	6	7.5	9	10	12	128	6.5	12.9	25.8	52	103	206	413	819
3.75	4	7.5	8	11.25	12	15	16	191	9.6	19.2	38.4	77	154	307	614	1219
5	5	10	10	15	15	20	20	255	12.8	25.6	51.2	102	205	410	819	1626

**Power Supply Voltage:**

Voltage: 24 VDC or 24 VAC (±10%)  
Current: 50 mA

**Digital Output:**

Form "C" Relay: 2 Amps @ 24 volts  
Electrical Life: 100,000 cycles @ 2 Amps  
Mechanical Life: 10 Million Operations

**Analog Input:**

Voltage/Impedance: 0-15 VDC/1M Ohms  
Current/Impedance: 0-20mA/250 Ohms

**Environmental Requirements:**

Operating Temperature: -20 to 150°F  
Operating Humidity: 10 to 95% non-condensing