

V221



V221

20A SPST Enclosed Relay With HOA Switch

Installer's Specifications

Operating Temperature	-40° to 60°C (-40° to 131°F)
Operating Humidity	10-90% RH, non-condensing
Expected Relay Life	Electrical (@ rated current) 100,000 cycles; Mechanical (unpowered) 10,000,000 cycles
Relay Status	LED ON=energized
Wire Specifications:	
Lead Length	14"(356mm) min.
Gauge	UL1015; Coil: 18AWG; Contacts: 12AWG; HOA monitor wires: 16AWG
Insulation Class	277VAC RMS
Agency Approvals	UL 508 enclosed device listing, pollution degree 2

⚠ DANGER ⚡

HAZARD OF ELECTRIC SHOCK, EXPLOSION, OR ARC FLASH

- Follow safe electrical work practices. See NFPA 70E in the USA, or applicable local codes.
- This equipment must only be installed and serviced by qualified electrical personnel.
- Read, understand and follow the instructions before installing this product.
- Turn off all power supplying equipment before working on or inside the equipment.
- Use a properly rated voltage sensing device to confirm power is off.
DO NOT DEPEND ON THIS PRODUCT FOR VOLTAGE INDICATION

Failure to follow these instructions will result in death or serious injury.

NOTICE

- This product is not intended for life or safety applications.
- Do not install this product in hazardous or classified locations.
- The installer is responsible for conformance to all applicable codes.
- Mount this product inside a suitable fire and electrical enclosure.

INSTALLATION

Disconnect and lock out all power sources before beginning the installation.

- Using the threaded nipple, connect the relay to the desired enclosure through a knock out hole.
- Secure with the conduit nut provided.
- Connect coil wires:
 - Choose the coil common lead (white with yellow stripe) and connect it to the common (-) source termination point.
 - Choose either the low voltage (10-30VAC/DC, white with blue stripe) or high voltage (208-277VAC, white with brown stripe) lead, depending on the application requirements, and connect it to the (+) source termination point.*

Note: When connecting the control side of this device (#18 wires) to power line circuits, provide current limiting at 7 amps max.
- Connect relay contacts:
 - Choose the two solid orange wires (N.O. contact) and connect to the switched load.

- Secure the enclosure and reconnect power.

* Isolate or insulate all non-terminated wires according to local electrical code requirements, i.e. wire nut.

DIMENSIONS

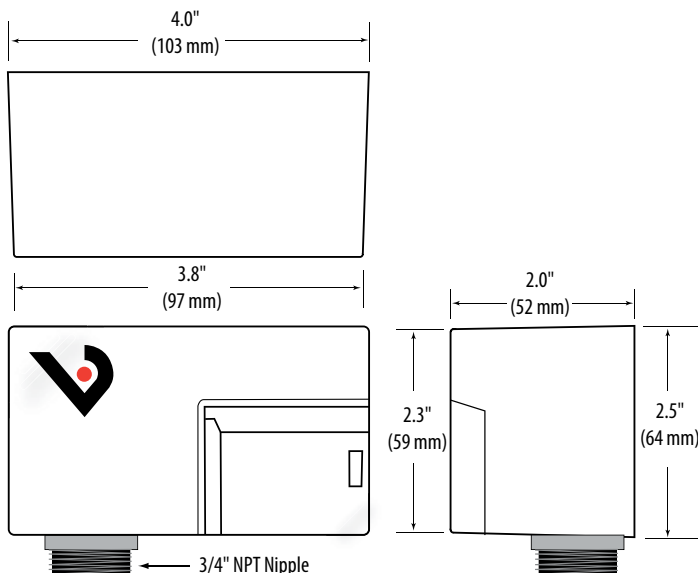

WIRING COLOR CODES

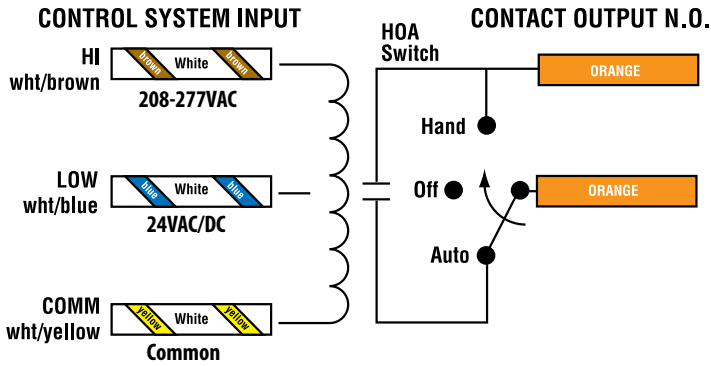

WIRING EXAMPLE

Nipple mount directly to a panel

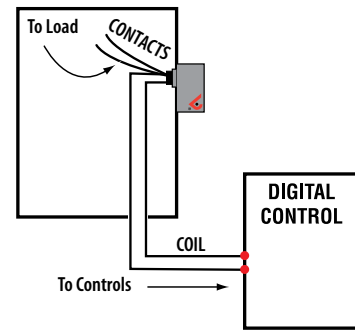

CONTACT AND COIL SPECIFICATIONS

TYPICAL COIL PERFORMANCE		
Coil Voltage 24VAC/DC, 208-277VAC		
Voltage	Coil Current	
	AC	DC
24V.....	75mA.....	32mA
208V.....	36mA	—
277V.....	49mA	—

CONTACT RATINGS	
Resistive.....	20A@240VAC
	8A@28VDC
	14A@14VDC
Motor.....	120VAC, 1HP N.O. & N.C.

Nipple mount to a 2x or 4x electrical box

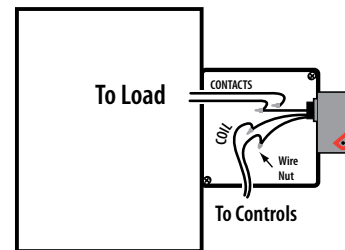

HOA POSITIONS

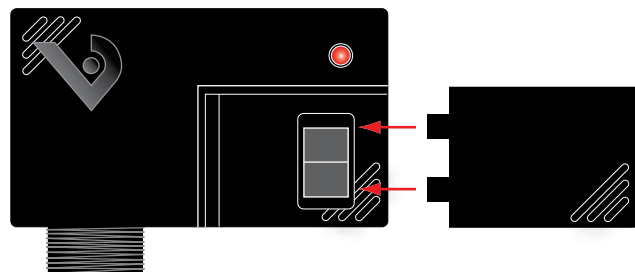

- HAND** Up position: contacts are closed.
- OFF** Middle position: contacts are open.
- AUTO** Down position: control system actuates the contacts.