

V122

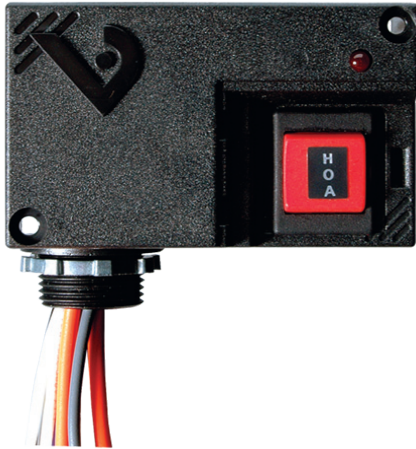

V122

20A SPST Enclosed Relay With Resistive HOA Monitor

Installer's Specifications

Operating Temperature	-40° to 60°C (-40° to 131°F)
Operating Humidity	10-90% RH, non-condensing
Expected Relay Life	Electrical (@ rated current) 100,000 cycles; Mechanical (unpowered) 10,000,000 cycles
Relay Status	LED ON=energized
Wire Specifications:	
Lead Length	14"(356mm) min.
Gauge	UL1015; Coil: 18AWG; Contacts: 12AWG; HOA monitoring wires: 16AWG
Insulation Class	277VAC RMS
Resistive Monitor Maximums:	
Voltage Max.	13.4VAC/DC
Current Max.	4mA AC/DC
Agency Approvals	UL 508 enclosed device listing, pollution degree 2

⚠ DANGER ⚡

HAZARD OF ELECTRIC SHOCK, EXPLOSION, OR ARC FLASH

- Follow safe electrical work practices. See NFPA 70E in the USA, or applicable local codes.
- This equipment must only be installed and serviced by qualified electrical personnel.
- Read, understand and follow the instructions before installing this product.
- Turn off all power supplying equipment before working on or inside the equipment.
- Use a properly rated voltage sensing device to confirm power is off.
DO NOT DEPEND ON THIS PRODUCT FOR VOLTAGE INDICATION

Failure to follow these instructions will result in death or serious injury.

NOTICE

- This product is not intended for life or safety applications.
- Do not install this product in hazardous or classified locations.
- The installer is responsible for conformance to all applicable codes.
- Mount this product inside a suitable fire and electrical enclosure.

DIMENSIONS

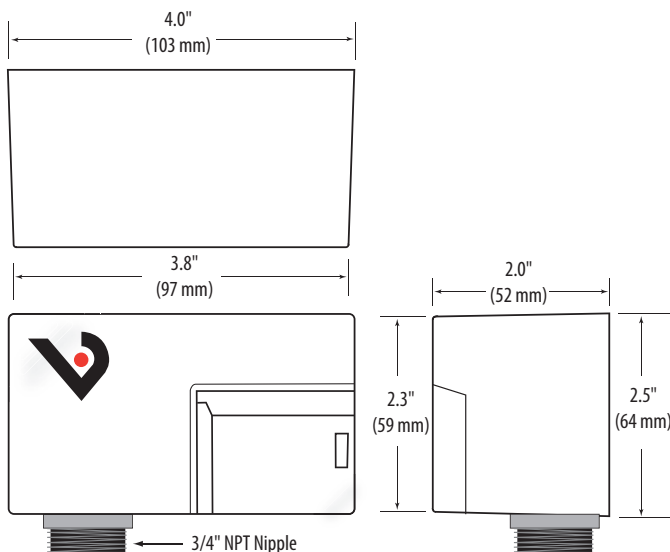

INSTALLATION

Disconnect and lock out all power sources before beginning the installation.

- Using the threaded nipple, connect the relay to the desired enclosure through a knock out hole.
- Secure with the conduit nut provided.
- Connect coil wires:
 - Choose the coil common lead (white with yellow stripe) and connect it to the common (-) source termination point.
 - Choose either the low voltage (10-30VAC/DC, white with blue stripe) or high voltage (120VAC, white with black stripe) lead, depending on the application requirements, and connect it to the (+) source termination point.*

Note: When connecting the control side of this device (#18 wires) to power line circuits, provide currenting limiting at 7 amps max.
- Connect relay contacts:
 - Choose the relay common wire (yellow) and connect to the switched load.
 - Choose the relay N.O. (orange) and/or* N.C. (blue) lead and connect to the switched load.
- Connect resistive HOA monitor wires:
 - Choose the two solid grey wires and connect them to a resistive (0-10kΩ) input in the control system.
- Secure the enclosure and reconnect power.
- Program the resistive input to the ranges listed.

* Isolate or insulate all non-terminated wires according to local electrical code requirements, i.e. wire nut.

WIRING COLOR CODES

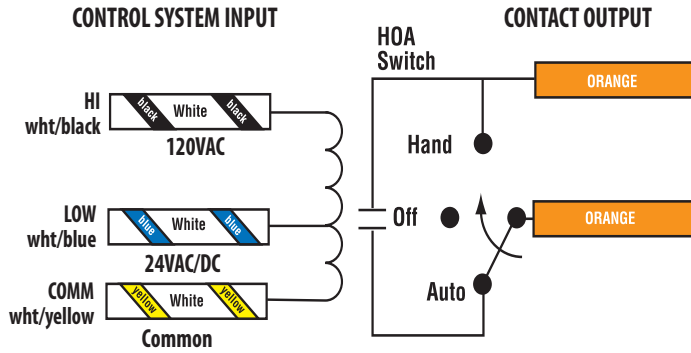

Resistive HOA Position Monitor

Switch Positions:
 HAND ~ 1.4KΩ
 OFF ~ 6.2KΩ
 AUTO ~ 3.4KΩ
CABLE FAULTS:
 OPEN = Infinite Ω
 SHORT ~ 0Ω

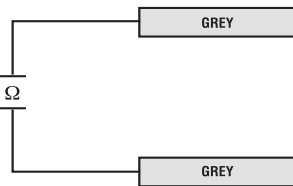

WIRING EXAMPLE

Nipple mount directly to a panel

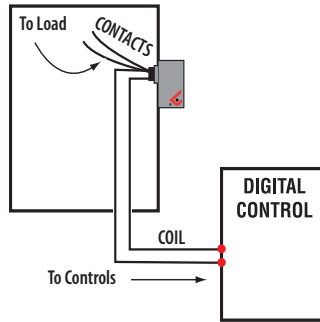

Nipple mount to a 2x or 4x electrical box

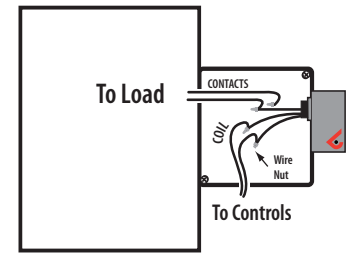

HOA POSITIONS

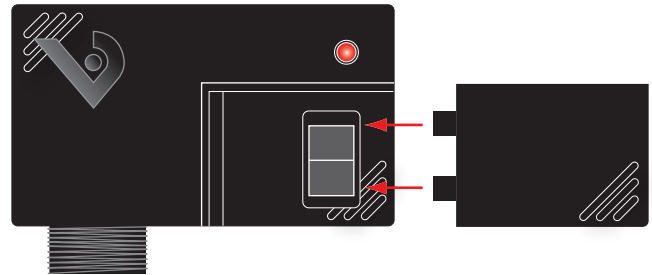

- HAND** Up position: contacts are closed.
- OFF** Middle position: contacts are open.
- AUTO** Down position: control system actuates the contacts.

CONTACT AND COIL SPECIFICATIONS

TYPICAL COIL PERFORMANCE		
Coil Voltage 24VAC/DC, 120VAC		
Voltage	Coil Current	
	AC	DC
24V.....	75mA.....	32mA
120V.....	22mA	—

CONTACT RATINGS	
Resistive.....	20A(r)@240VAC 8A@28VDC 14A@14VDC
Motor.....	250VAC, 1HP N.O. & N.C.

PROGRAMMING THE RESISTIVE MONITOR

The resistive monitor is a 0-10 kΩ analog output for monitoring the HOA switch position. Please use the following ranges for the DDC scaling.

Condition	Range* (Ω)	Nominal Values without Wire Resistance* (Ω)
Line Open	Greater than 8630	n/a
HOA Off	5290 to 8630	6190
HOA Auto	2880 to 5289	3391
HOA On	1200 to 2879	1406
Line Shorted	Less than 1200	n/a

* Ranges based on the presence of 0-1000 Ω of resistance due to wire. Average # of feet for 1000Ω by wire AWG listed below.

Wire Type (AWG)†	Distance Allowed (ft.)
26	12,189
22	30,864
18	78,296

† All 2-wire runs