

V100DC

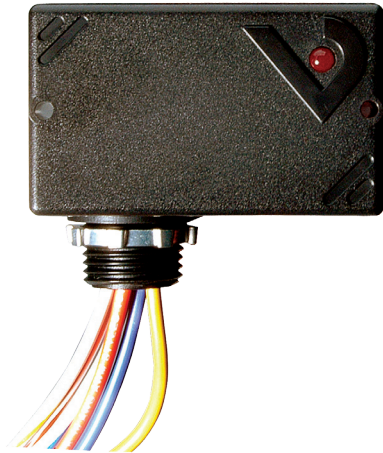

V100DC

10A SPDT Enclosed Relay

10-30 VDC Coil

Installer's Specifications

Operating Temperature	-34°C to 60°C (-29° to 140°F)
Operating Humidity	10-90% non condensing
Expected Relay Life	Electrical (at rated current): 100,000 cycles Mechanical (unpowered): 10,000,000 cycles
Relay Status	LED ON=energized
Wire Specifications:	
Lead Length	14" (356mm) min.
Gauge	UL1015; Coil: 18 AWG; Contacts: 16 AWG
Insulation Class	600 VAC RMS
Agency Approvals	UL508 enclosed device listing

⚠ DANGER ⚡

HAZARD OF ELECTRIC SHOCK, EXPLOSION, OR ARC FLASH

- Follow safe electrical work practices. See NFPA 70E in the USA, or applicable local codes.
- This equipment must only be installed and serviced by qualified electrical personnel.
- Read, understand and follow the instructions before installing this product.
- Turn off all power supplying equipment before working on or inside the equipment.
- Use a properly rated voltage sensing device to confirm power is off.
DO NOT DEPEND ON THIS PRODUCT FOR VOLTAGE INDICATION

Failure to follow these instructions will result in death or serious injury.

NOTICE

- This product is not intended for life or safety applications.
- Do not install this product in hazardous or classified locations.
- The installer is responsible for conformance to all applicable codes.
- Mount this product inside a suitable fire and electrical enclosure.

INSTALLATION

Disconnect and lock out all power sources before beginning the installation.

- Using the threaded nipple, connect the relay to the desired enclosure through a knock out hole.
- Secure with the conduit nut provided.
- Connect Coil:
 - Choose the coil common lead (white with yellow stripe) and connect it to the (-) source termination point.
 - Choose the low voltage (10-30 VAC/DC, white with blue stripe) lead, and connect it to the (+) source termination point.*
- Connect Relay Contacts:
 - Choose the relay common wire (yellow) and connect to switched load.
 - Choose the relay N.O. (orange) and/or* N.C. (blue) lead and connect to switched load.

5. Secure the enclosure and reconnect power.

** Isolate or insulate all non-terminated wires according to local electrical code requirements, i.e. wire nut.*

DIMENSIONS

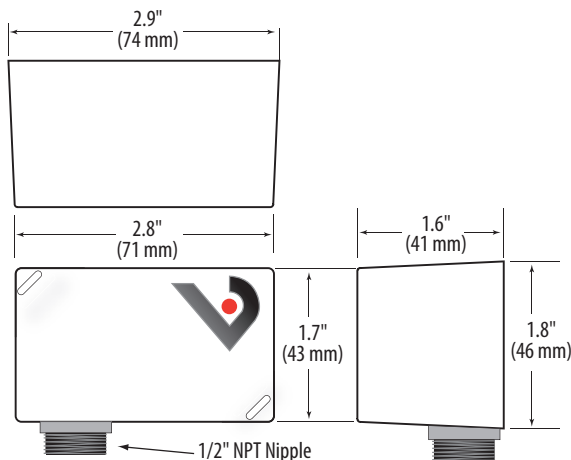

WIRING COLOR CODES

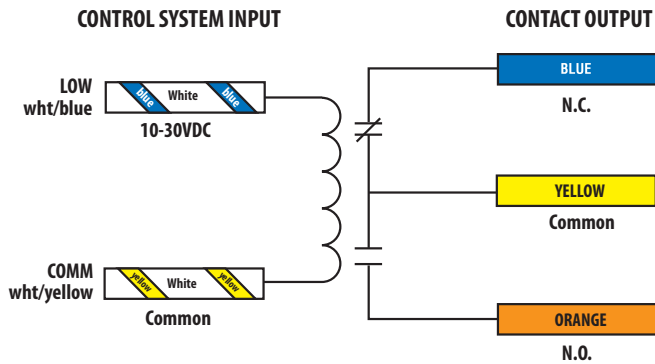

WIRING EXAMPLE

Nipple mount directly to a panel

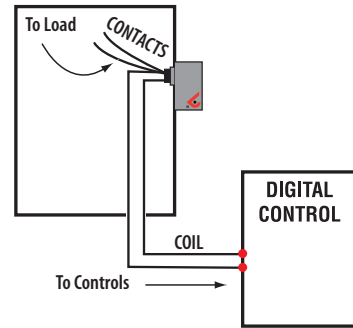

CONTACT AND COIL SPECIFICATIONS

TYPICAL COIL PERFORMANCE	
Pull in Voltage	DC
10-30V.....	9
Drop Out Voltage	DC
10-30V.....	3
Voltage	Coil Current
	DC
10V.....	14mA
12V.....	14mA
24V.....	16mA
30V.....	18mA

CONTACT RATINGS	
Resistive	10A@277VAC, 28VDC
Motor	120VAC, 1/3HP N.O. & 1/6HP N.C. 240VAC, 1/3HP N.O. & 1/6HP N.C. 277VAC, 1/4HP N.O. & 1/8HP N.C.
Pilot Duty	277VAC, (1.7A), 480VA N.O.
Ballast	277VAC, 1.7A
Tungsten	120VAC, TV3 N.O. TV2 N.C.
Gold Flash	Yes

Nipple mount to any 2x or 4x electrical box

