

**SCADA 3000**  
**RELAY OUTPUT MODULE**

Every effort has been made to ensure that the information in this supplement is complete, accurate and up-to-date. Phonetics, Inc. assumes no responsibility for the results of errors beyond its control. Phonetics, Inc. also cannot guarantee that changes in equipment made by other manufacturers, and referred to in this supplement, will not affect the applicability of the information in this manual.

Copyright 1999 by Phonetics, Inc.

First Edition, version 1.0, June 1, 1999.

Written and produced by Phonetics, Inc.

Please address comments on this publication to:

Phonetics Inc.  
901 Tryens Road  
Aston, PA 19014

Sensaphone is a registered trademark of Phonetics, Inc.

For information on updates to the manual and supplements, check our website at

[www.sensaphone.com](http://www.sensaphone.com)

## IMPORTANT SAFETY INSTRUCTIONS

Your RELAY OUTPUT MODULE has been carefully designed to give you years of safe, reliable performance. As with all electrical equipment, however, there are a few basic precautions you should take to avoid hurting yourself or damaging the unit:

- Read the installation and operating instructions in this manual carefully. Be sure to save it for future reference.
- Read and follow all warning and instruction labels on the product itself.
- To protect the Relay Output Module from overheating, make sure all openings on the unit are not blocked. Do not place on or near a heat source, such as a radiator or heat register.
- Do not use your Relay Output Module near water, or spill liquid of any kind into it.
- Be certain that your power source matches the rating listed in the specification section of this manual. If you're not sure of the type of power supply to your facility, consult your dealer or local power company.
- Do not allow anything to rest on the power cord. Do not locate this product where the cord will be abused by persons walking on it.
- Do not overload wall outlets and extension cords, as this can result in the risk of fire or electric shock.
- Never push objects of any kind into this product through ventilation holes as they may touch dangerous voltage points or short out parts that could result in a risk of fire or electric shock.
- To reduce the risk of electric shock, do not disassemble this product, but return it to Phonetics' Customer Service, or another approved repair facility, when any service or repair work is required. Opening or removing covers may expose you to dangerous voltages or other risks. Incorrect reassembly can cause electric shock when the unit is subsequently used.
- If anything happens that indicates that your Universal Input Module is not working properly or has been damaged, disconnect it immediately and follow the procedures in the manual for having it serviced. Return the unit for servicing under the following conditions:
  1. Liquid has been spilled into the product or it has been exposed to water.
  2. The unit has been dropped, or the enclosure is damaged.
  3. The unit doesn't function normally when you're following the operating instructions.

### FCC Requirements

**Part 15:** This equipment has been tested and found to comply with the limits for a Class A digital device, pursuant to Part 15 of the FCC Rules. These limits are designed to provide reasonable protection against harmful interference when the equipment is operated in a commercial environment. This equipment generates, uses and can radiate radio frequency energy and, if not installed and used in accordance with the instructions, may cause harmful interference to radio communications. Operation of this equipment in a residential area is likely to cause harmful interference in which case the user will be required to correct the interference at his own expense.

# Relay Output Module Supplement

## Contents

<b>Important Safety Instructions .....</b>	<b>3</b>
<b>FCC Requirements .....</b>	<b>3</b>
<b>INTRODUCTION .....</b>	<b>5</b>
<b>Technical Support .....</b>	<b>5</b>
<b>INSTALLATION .....</b>	<b>6</b>
<b>Environment .....</b>	<b>6</b>
<b>Mounting .....</b>	<b>6</b>
<b>Power Supply and Grounding .....</b>	<b>7</b>
<b>Communications Wiring .....</b>	<b>7</b>
<b>Cabling Notes .....</b>	<b>8</b>
<b>Bus Termination .....</b>	<b>9</b>
<b>Notes on Correct Use .....</b>	<b>10</b>
<b>HOW THE RELAY OUTPUT MODULE WORKS .....</b>	<b>11</b>
<b>Appendix A: Specifications .....</b>	<b>12</b>
<b>Appendix B: Troubleshooting .....</b>	<b>13</b>
<b>Appendix C: Replacement Parts .....</b>	<b>14</b>
<b>Appendix D: Returning Module for Service .....</b>	<b>15</b>
<b>WARRANTY.....</b>	<b>16</b>

# Introduction

The SCADA 3000 Relay Output Module is an optional component for use with the SCADA 3000 system. The output channels are identical to those included on the SCADA 3000 main unit. The Relay Output Module features eight latching relay outputs that can be used to switch equipment on and off. The relays are rated at 2 Amps at 125VAC and have integral contact protection. They may be controlled manually or automatically via a ladder program or C-program. In addition, a microprocessor watchdog circuit is integrated to maintain system reliability. LED indicators are provided to show system power and module operation via a blinking pulse LED.

## Technical Support

If any questions arise upon installation or operation of the Universal Input Module, please contact Phonetics Customer Service Department at the number shown below and have the following information:

- Date of purchase \_\_\_\_\_
- Serial number \_\_\_\_\_

Technical support is available from 8:00 AM to 5:00 PM, EST.

You can also contact technical support at any time via e-mail at: [support@sensaphone.com](mailto:support@sensaphone.com)

**Phonetics, Inc.**  
901 Tryens Road  
Aston, PA 19014  
Phone: (610)558-2700  
FAX: (610)558-0222  
[www.sensaphone.com](http://www.sensaphone.com)

# INSTALLATION

This chapter provides information necessary to install the Relay Output Module. Correctly installing the unit will ensure proper functioning and maximum service life. Please read the entire chapter before attempting installation.

## OPERATING ENVIRONMENT

The Relay Output Module should be mounted and operated in a clean, dry and safe environment. Do not mount the unit where it will be subject to shock and vibration. Do not mount the unit where it will be subject to dirt, dust or moisture. Ideally the unit would be mounted in a steel or a fiberglass NEMA-4 enclosure. Do not mount the unit or the expansion modules close to motor starters or contactors that switch inductive loads. These devices generate large electromagnetic fields that can cause the Relay Output Module to malfunction. Where this is unavoidable, mount the module(s) and main unit in a separate, grounded, steel enclosure. This will shield them from harmful electrical interference.

The temperature range the Relay Output Module can operate in is 32°F to 158°F (0°C to 70°C). If you require Relay Output Module to operate in a below freezing environment, you must take safe and practical measures to keep the module's temperature above 32°F or it will not operate reliably.

**CAUTION:** The Relay Output Module is a sensitive electronic device. Personnel and work area should be grounded before handling this device. Do not install a SCADA 3000 system near any strong electrostatic, electromagnetic, magnetic or radioactive fields. Do not expose it to fumes or corrosive vapors.

## MOUNTING THE RELAY OUTPUT MODULE

When you receive the Relay Output Module, carefully remove it from the box. On the top and bottom of the enclosure are mounting holes to attach the unit to either a panel or wall. The mounting surface should be sturdy enough to support 2 lbs. The unit should be mounted using four #10-32 bolts where appropriate, or four #10 tapping screws. (The screw kit for the Relay Output Module includes 4 #10-32 screws, 4 #10-32 nuts, 4 #10 lockwashers, and 2 #6-32 screws, 2 #6-32 nuts, and 2 #6 lockwashers. The #6 hardware is for the power supply, if necessary.)

When mounting the unit to a wall make sure the mounting screws fully engage a solid member (for example, a stud) of the support structure. Mount the Relay Output Module in an upright position so that you can easily connect wires to the terminal strips. The dimensions of the full enclosure are: 6.1" x 6.3" x 1.2". See Figure 1.

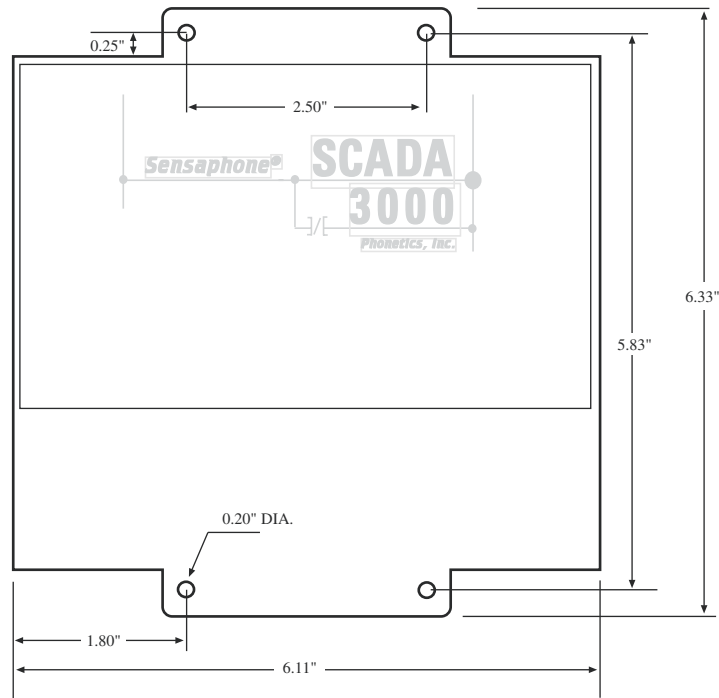

Figure 1: Mounting Diagram

### Power Supply and Grounding

The Relay Output Module operates on 10-15VDC. Typically the module is powered from the AUX PWR terminals on the SCADA 3000 main unit. This is preferred because the AUX PWR from the main unit is battery-backed in the event of a power failure, when a battery is connected to the main unit. Alternately, you may connect the module to any 10-15VDC power source.

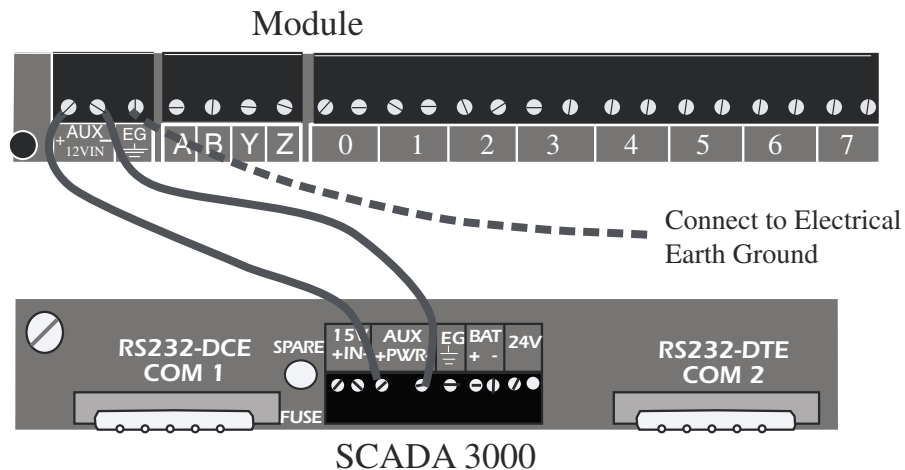

Figure 2: Module powered from main unit

It is extremely important that the EG pin be connected to a good earth ground. This will prevent communication errors due to differences in ground potential between modules in addition to possible damage due to voltage transients and surges.

The two LED lights in the center of the module, marked *Power* and *Pulse*, indicate that the

module is receiving power and operating properly. The Pulse LED will blink at a regular rate, like a heartbeat, once it establishes communication with the main unit.

**Communications Wiring**

The Relay Output Module communicates with the SCADA 3000 using a high-speed serial communications bus. This 4-wire bus is used to connect up to 15 modules to the main unit to provide additional inputs and/or outputs. The communications cable must be **4-Conductor Twisted Pair**. You may use unshielded cable in electrically quiet environments, but be sure to use shielded cable if your cabling must navigate around electrical machinery or equipment.

Modules may be located a maximum of 2000' away from the main unit and should be connected in a daisy-chain fashion from one module to the next. Each module connects to the next via a 4-wire communications cable connected to the terminals labeled **A,B, Z & Y**. The cable must be **4-Conductor Twisted Pair** (shielded or unshielded) with a nominal impedance of 120Ω (for example, Belden #8132 or 9842 cable). Use one pair for A & B and the other pair for Z & Y. Note how the wiring is reversed between the first module and the main unit but between modules the wiring is straight-thru. Correct wiring setup is shown in Figure 3.

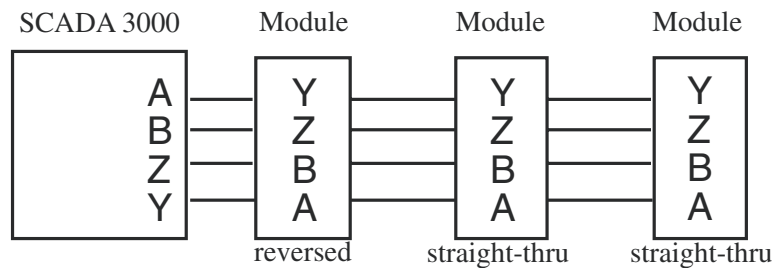

Figure 3: **Correct** daisy chain setup: Main unit on the end.

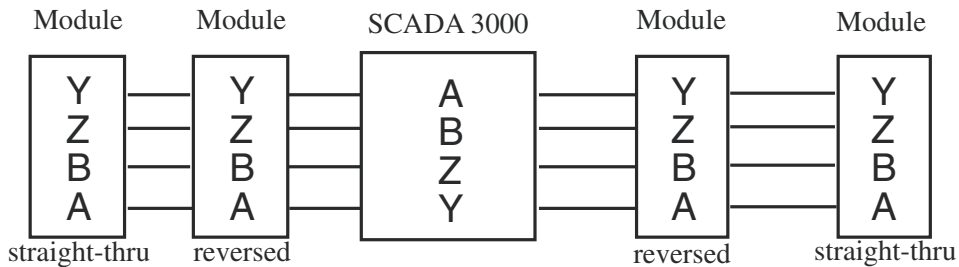

Figure 4: **Incorrect** daisy chain setup: Main unit in the middle of the chain.

**The Main Unit should always be on one end of the chain, never in the middle.**

**Cabling Notes**

Follow these guidelines to protect the communications cable from electrical interference.

- Keep the communications cable at least five feet from any electric motors, transformers, rectifiers, generators, arc welders, induction furnaces, or sources of microwave radiation.
- If you must run the cable across power lines, run them at right angles to the lines.
- Keep the communications cable at least 6 inches from AC power lines carrying less than 20A, at least 1 foot from lines greater than 20A, and 2 feet from lines greater than 100KVA.
- If you run the cable in a metallic wireway or conduit, keep the communications



cable at least 3 inches from AC power lines carrying less than 20A, at least 6 inches from lines greater than 20A, and 1 foot from lines greater than 100KVA.

Running the communications cable through conduit provides extra protection from physical damage and electrical interference. If you route the cable through conduit be sure to ground the entire length by connecting it to the building earth ground. For best results, use ferromagnetic conduit near critical sources of electrical interference. You can use aluminum conduit in non-critical areas.

Each module must be configured with its own **unique** address using the BUS ADDRESS jumpers. You may mix & match up to 15 modules to suit your application's requirements. The example below shows a Bus Address setting of 9.

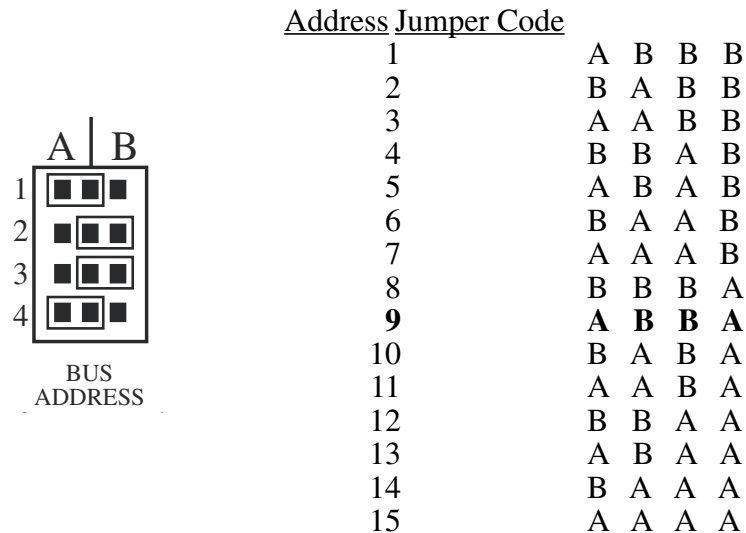

Figure 5: Setting the Bus Address

## Bus Termination

Located on each module is a jumper labeled BUS TERM. This jumper is used to terminate the 4-wire communications bus.

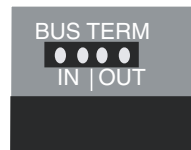

Figure 6: Bus Termination jumper

Termination is required at the extreme ends of the communications network to minimize signal reflections that would otherwise cause data communication errors. To activate the Bus Termination, move the jumper to the IN position. Note that this should only be activated if the module is at the very end of the network. All other modules in between should have the termination set to the OUT position. As a result, only 1 module (plus the main unit) should ever have the termination activated. The diagram following illustrates proper termination of the communications bus.

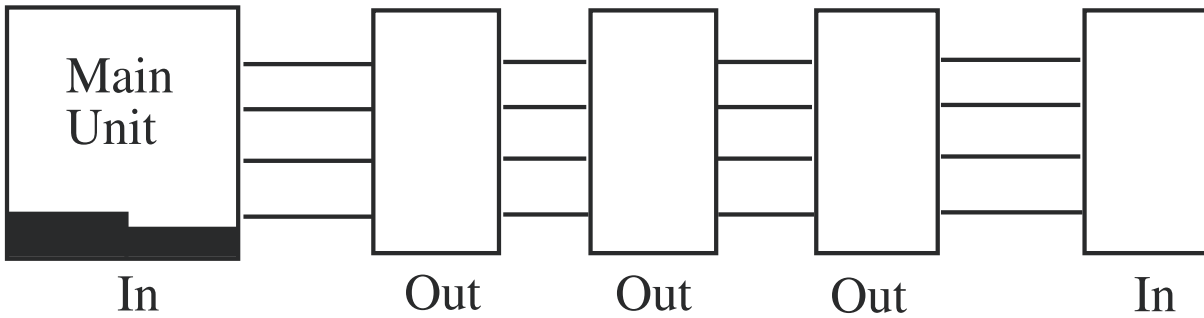

Figure 7: Correct bus termination

**Notes on Correct Use**

The Relay Output Module can be used to control a wide variety of AC and DC devices. However, care must be taken to insure that the module is not used in such a way that will severely degrade the life expectancy of the relays or cause the Relay Output Module to malfunction (e.g. microprocessor reset). Do not continuously apply a voltage higher than the rated maximum voltage to any relay. Do not switch loads that exceed the rated capacity of the relay. Avoid switching high-current inductive loads as these will generate significant radiated noise when switching, possibly causing the microprocessor to reset. Also, do not run your output wiring together with your input wiring. This will almost always cause errors in your input readings because of signal coupling. Be sure to follow National Electric Code guidelines for proper wiring and safety when working with high voltage circuits. See the Specifications in appendix A for complete rating information.

The following wiring diagram shows a typical switching application.

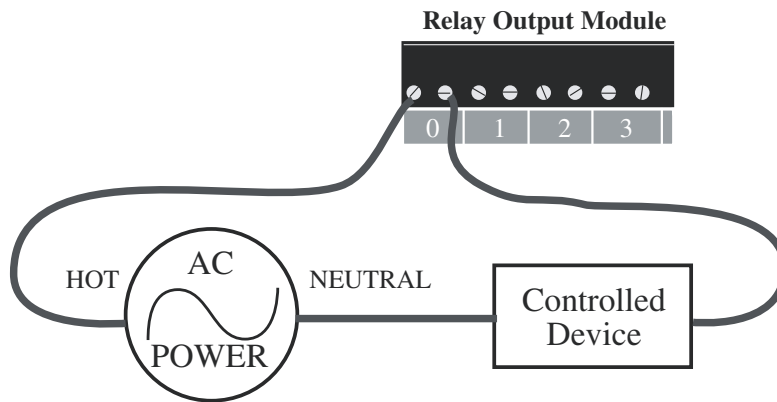

Figure 8: Relay Output Wiring

The output wiring terminals are designed to accept #14AWG to #24AWG stranded wires. Be sure to use wire of the proper type and gauge for your application. The recommendations listed below will minimize interference to other signals.

- Route the power supply and communications cables to the module by a separate path from wiring to I/O devices. Where paths must cross, their intersection should be perpendicular.
- Do not run signal or communications wiring and power in the same conduit.
- Segregate I/O wiring by signal type. Bundle wiring with similar electrical characteristics together.
- Allow at least two inches between the module and I/O wiring ducts.

The three terminal blocks on the Relay Output Module are all removable for faster and more convenient wiring of the I/O module. They should only be removed or attached when power to the module is OFF. To remove the terminal blocks use your thumb or forefinger to push the screw section of the terminal block straight out (see figure below).

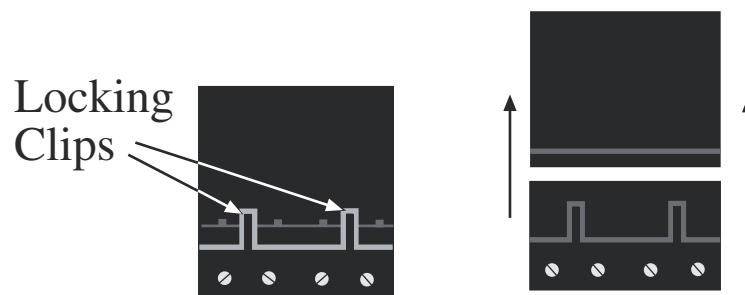

Figure 9: Removing terminal blocks

## HOW THE RELAY OUTPUT MODULE WORKS

The Relay Output Module contains eight independent latching relays that are controlled by the SCADA 3000 CPU. They may be controlled manually while online with the SCADA 3000 or automatically using a ladder program or C-program. Specific information regarding output control using the Ladder & C-Programs can be found in the SCADA 3000 CPU manual. A latching relay is one that retains (latches) its contact position even if power fails. Thus, if the Relay Output Module loses power, the relay will maintain its last state until it receives a new instruction to change its state. The output relays may be used to control a variety of devices such as lighting, small motors or pumps, computer equipment, or alarm signaling devices.

To program the Relay Output Module, click on the Relay Output icon on the main unit form. The icon will appear at its corresponding address and will be designated by the letters “RO.”

# Appendix A Specifications

<b>8 LATCHING RELAY OUTPUTS</b>	
<b>Rated Load (resistive)</b>	2A 125VAC, 2A 30VDC
<b>Rated Load (inductive)</b>	1A 125VAC, 1A 30VDC
<b>Max. Operating Voltage</b>	125VAC, 125VDC
<b>Max. Switching Capacity (resistive)</b>	125VA, 60W
<b>Max. Switching Capacity (inductive)</b>	125VA, 30W
<b>Minimum permissible load</b>	10mA, 5VDC
<b>Contact Protection</b>	275V Metal-Oxide-Varistor on each output
<b>Network Data Rate</b>	153.6 Kbps
<b>Bus Termination Impedance</b>	120 Ohms
<b>Power Requirements</b>	10-15VDC 80mA, 1.2W
<b>Power Fuse Rating &amp; type</b>	500mA 250V, Size TR-5 (Wickmann # 19372-041-K)
<b>Operating temperature</b>	0 to 70 degrees Celsius (32 to 158 degrees F)
<b>Storage Temperature</b>	-20 to 70 degrees Celsius (-4 to 158 degrees F)
<b>Humidity</b>	5 to 90% non-condensing
<b>Dimensions</b>	6.1" x 6.3" x 1.2"
<b>Weight</b>	0.75 lbs.
<b>Enclosure</b>	Aluminum Housing with integral mounting flanges for wall or panel installation.

# Appendix B: Troubleshooting

Problem: I have power wired to the Relay Output Module but the green LED is off.
Solution: You probably have a blown fuse. Check your wiring and replace the fuse.
Problem: The green LED is on but yellow LED is off.
Solution: This means that the module and main unit are not communicating. It could be a problem with either device. Check the communications wiring first. Make sure the main unit is on and functioning. Verify that the module address is valid and unique. Try powering up both devices.

## Appendix C: Replacement Parts

This appendix provides a list of replacement parts and part numbers for the FGD-3040 Relay Output Module. Contact the Phonetics Customer Service Department at (610)558-2700 for availability.

ASY-0051	Relay Output Module Circuit Board
CON-0027	16 Position Terminal Block Plug
CON-0033	2 Position Jumper Shunt
CON-0101	8 Position Terminal Block Plug
CON-0106	3 Position Terminal Block Plug
FUS-0005	500 mA 250V TR5-style Time-Lag Fuse (Wickmann #3720500041)
HSG-0022	Enclosure Base
HSG-0046	Enclosure Cover
LIT-0033	SCADA 3000 Relay Output Module Owner's Manual Supplement

# Appendix D: Returning Module for Service

In the event that the Relay Output Module does not function properly, we suggest that you do the following:

- 1) Record your observations regarding the Relay Output Module malfunction.
- 2) Call the Customer Service Department at (610)558-2700 prior to sending the unit to Phonetics for repair.

If the module must be sent to Phonetics for Servicing, please do the following:

- 1) Disconnect all wiring and unplug the unit.  
Note that the terminal blocks can be unplugged from the unit to maintain your input wiring.
- 2) Carefully pack the module to avoid damage in transit. Use the original container (if available) or a sturdy shipping box.
- 3) You must include the following information to avoid shipping delays:
  - a) Your name, address and telephone number.
  - b) A note explaining the problem.
- 4) Ship your package to the address below:
 

SERVICE DEPARTMENT  
Phonetics Inc.  
901 Tryens Road  
Aston, PA 19014
- 5) Ship prepaid and insured via UPS or US Mail to ensure a traceable shipment with recourse for damage or replacement.

## Important Information for Canadian Customers

In the event that your Sensaphone Thermocouple Input Module does not function properly, Canadian customers have the option of shipping the unit to one of the following Phonetics-authorized Canadian Repair facilities:

Microwise Computer Systems  
100 Covington Crescent  
Kitchener, Ontario N2N 2X3  
(519) 744-9892

G.A.S. Analytical Systems, Ltd.  
Head Office  
Bay V, 1338 36 Avenue NE  
Calgary, Alberta T2E 6T6  
(403) 253-6576

Please record your observations regarding the unit's malfunction and follow the procedures outlined on the previous page.

For Technical Support questions, you may call Phonetics Technical Service Department at (610) 558-2700, or by E-mail at [support@sensaphone.com](mailto:support@sensaphone.com).

### 3 YEAR LIMITED WARRANTY

1. **WARRANTOR:** Dealer, Distributor, Manufacturer
2. **ELEMENTS OF WARRANTY:** This Product is warranted to be free from defects in materials and craftsmanship with only the limitations and exclusions set out below.
3. **WARRANTY AND REMEDY: Three-Year Warranty** — In the event that the Product does not conform to this warranty at any time during the time of three years from original purchase, warrantor will repair the defect and return it to you at no charge

This warranty shall terminate and be of no further effect at the time the Product is (1) damaged by extraneous cause such as fire, water, lightning, etc. or not maintained as reasonable and necessary; (2) modified; (3) improperly installed; (4) repaired by someone other than warrantor; (5) used in a manner or purpose for which the Product was not intended; or (6) sold by original purchaser.

WARRANTORS' OBLIGATION UNDER THIS WARRANTY IS LIMITED TO REPAIR OR REPLACEMENT OF THE PRODUCT. THIS WARRANTY DOES NOT COVER PAYMENT OR PROVIDE FOR THE REIMBURSEMENT OF PAYMENT OF INCIDENTAL OR CONSEQUENTIAL DAMAGES.

It must be clear that the warrantors are not insuring your premises or guaranteeing that there will not be damage to your person or property if you use this Product. The warrantors shall not be liable under any circumstances for damage to your person or property or some other person or that person's property by reason of the sale of this product or its failure to operate in the manner in which it is designed. The warrantors' liability, if any, shall be limited to the original cost of the Product. The warrantors assume no liability for installation of the Product and/or interruptions of the service due to strikes, riots, floods, fire, and/or any cause beyond Seller's control.

4. **PROCEDURE FOR OBTAINING PERFORMANCE OF WARRANTY:** In the event that the Product does not conform to this warranty, the Product should be shipped or delivered freight prepaid to a warrantor with evidence of original purchase.
5. **LEGAL REMEDIES:** This warranty gives you specific legal rights, and you may also have other rights which vary from state to state to the extent allowed by law expressly in lieu of any other express or implied warranty, condition, or guarantee.

Effective date: 1 June 1999

Phonetics, Inc.

901 Tryens Road

Aston, PA 19014

Phone: (610) 558-2700 Fax: (610) 558-0222