

Deluxe Duct & Outdoor Humidity Sensors

1% & 2% NIST, or Standard 2%, 3%, or 5%



DESCRIPTION

HD and HO Deluxe humidity transmitters provide an ideal solution for measuring relative humidity in a wide range of conditions. All devices are equipped with a thin-film capacitive sensor that is easily replaceable in the field. These sensors are calibrated to NIST standards, with certificates available (see Ordering Information; choose "N" in NIST block). Temperature sensing options are also available.

The duct mounted HD is encased in a die cast metal housing for extra strength. The outdoor HO housing is completely weather proof – the most rugged sensor available.

All Deluxe models come with a standard five-year warranty.

APPLICATIONS

- Controlling HVAC systems for improved comfort and energy savings
- Museums, schools, printing shops, and other locations requiring humidity control
- Facilitating compliance with ASHRAE standards for environmental control and indoor air quality

SPECIFICATIONS



Input Power:*

Voltage Model	12-30VDC/24VAC, 15mA max.
mA Model	Loop powered 12-30VDC only, 30mA max.

Output Power:

Voltage Model	3-wire, observe polarity
mA Model	2-wire, not polarity sensitive (clipped and capped)

Humidity:

HS Element	Digitally profiled thin-film capacitive (32 bit mathematics) U.S. Patent 5,844,138†
Accuracy at 25°C from 10-80% RH**	±1% (HD only), 2%, 3%, or 5% (specify); multi-point calibration, NIST traceable
Temperature Effect, Duct Model	±0.1% RH/°C above or below 25°C (typical)
Temperature Effect, Outdoor Model	4-20mA version: (0.0013x%RHx(T°C-25)); 0-5 V/0-10V versions: (0.0015x%RHx(T°C-25))-(%RHx0.0008xabs(T°C-25))
Scaling	0-100% RH
Hysteresis	1.5% typical
Linearity	Included in accuracy spec.
Reset Rate***	24 hours
Stability	±1%@20°C (68°F) annually, for two years

Temperature:

Optional Temperature Transmitter Output	Digital, 4-20mA (clipped and capped) or 0-5V/0-10V output; HO transmitter accuracy: ±1.3°C (±2.3°F) typical; HD transmitter accuracy: ±0.5°C (1.0°F) typical
--	---

Operating Environment:

Operating Humidity Range	0 to 100% RH noncondensing
Operating Temperature Range	-40° to 50°C (-40° to 122°F)

† The HS sensing element has a 1-year warranty. The element is not a part of the 5-year product warranty.

* One side of transformer secondary is connected to signal common, so an Isolation transformer or dedicated power supply may be required.

** Specified accuracy with 24VDC supplied power with rising humidity. RTD/Thermistors are not compensated for internal heating of product.

*** Reset Rate is the time required to recover to 50% RH after exposure to 90% RH for 24 hours.

Shielded cabling is required for conformance to EMC standards. Technical information is available from factory upon request or is available on our website: www.veris.com.

EMC Conformance - CE Option: Low Voltage Directive 2006/95/EC and EMC Directive 2004/108/EC.

EMC Special Note: Connect this product to a DC distribution network or an AC/DC power adaptor with proper SURGE PROTECTION (EN 61000-6-1:2007 specification requirements).

APPLICATION/WIRING DIAGRAMS

HD/HO 0-5V/0-10V Temperature Transmitter Versions

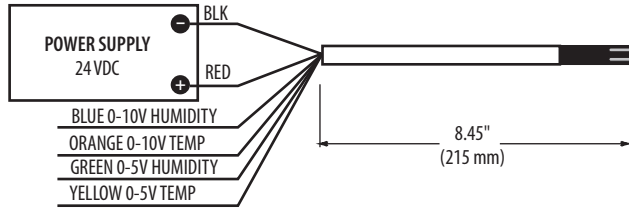

HO (0-5V/0-10V Resistance Versions)

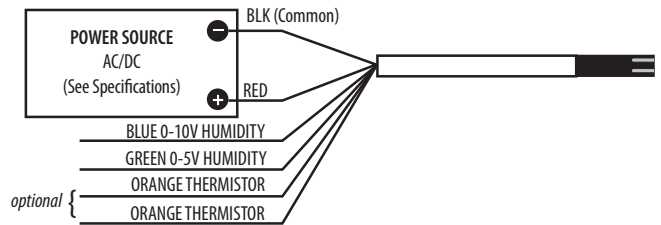

HD/HO 4-20mA Temperature Transmitter Versions

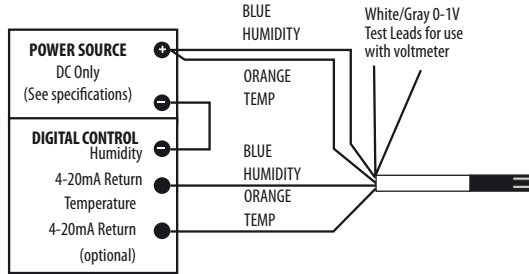

HO 4-20mA Resistance Versions

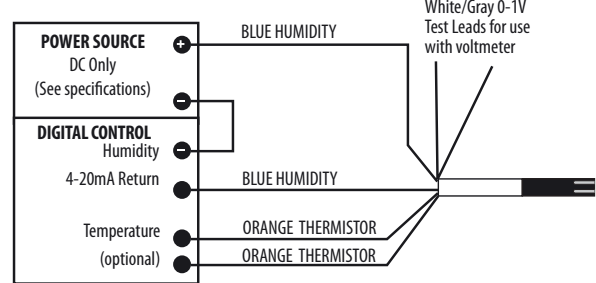

DIMENSIONAL DRAWINGS

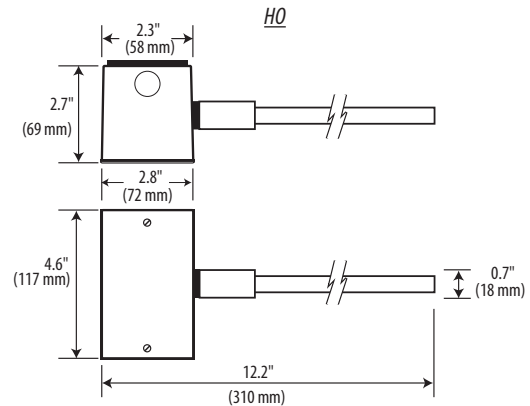
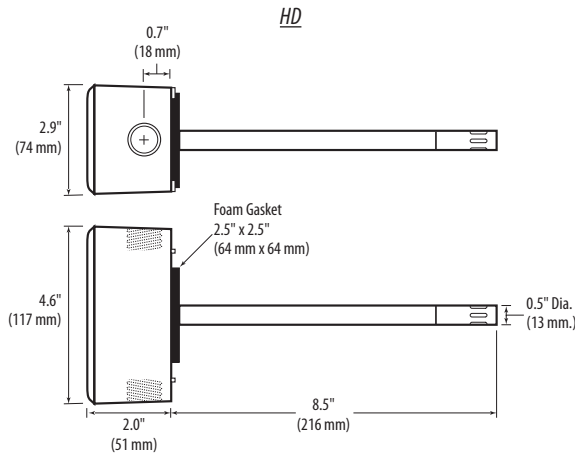

ORDERING INFORMATION



Enclosure	Accuracy	NIST	Output	US or EU	Temp.
H <input type="checkbox"/>	<input type="checkbox"/>	<input type="checkbox"/>	<input type="checkbox"/>	<input type="checkbox"/>	<input type="checkbox"/>
D = RH Duct	1 = 1%	N = NIST 1% & 2% only	M = 4-20mA	S = Standard	T = Temp
O = Outdoor	2 = 2%	X = None 2%, 3%, 5% only	V = 0-5V/0-10VDC	C = CE	X = No Temp (Stop here)
	3 = 3%				
	5 = 5%				
	(1% not available on HO)				

Example: (No Temp)

H 0 2 X M S X

Example: (With Temp)

H D 2 N V C T C 2

ACCESSORIES

Water guard (AA42)
Replacement humidity element (HS)



Humidity Transmitter Combination

Sensor Type	Range	OPTION Temp Cert
<input type="checkbox"/> A	<input type="checkbox"/>	<input type="checkbox"/>
= Transmitter	1 = -40° to 50°C (-40° to 122°F)	Blank = None
	2 = 0° to 50°C (32° to 122°F)	1 = 1pt Cal
		2 = 2pt Cal

Humidity RTD/Thermistor Combination

Sensor Type	OPTION Temp Cert
<input type="checkbox"/>	<input type="checkbox"/>
B = 100R Platinum, RTD	Blank = None
C = 1k Platinum, RTD	1 = 1pt Cal
D = 10k T2, Thermistor	2 = 2pt Cal
E = 2.2k, Thermistor	
F = 3k, Thermistor	
G = 10k CPC, Thermistor	
H = 10k T3, Thermistor	
J = 10k Dale, Thermistor	
K = 10k with 11k shunt, Thermistor	
M = 20k NTC, Thermistor	
N = 1800 ohm TAC, Thermistor	
Q = 1uA/°C, Linitemp	
R = 10k US, Thermistor	
S = 10k 3A 221, Thermistor	
T = 100k, Thermistor	
U = 20k "D", Thermistor	
W = 10k T2 high accuracy, Thermistor	
Y = 10k T3 high accuracy, Thermistor	
Z = 10k E1, Thermistor	