

H970HCA



Hawkeye™ 970HCA

Split-Core Low Current 4-20mA & 0-5VDC DC Current Transducer

Installer's Specifications

Technology	Open loop Hall effect
Amperage Range	0 to 50/100/200 ADC (slide switch selectable)
Sensor Supply Voltage	15-30VAC/DC for 4-20mA output; 12-30VAC/DC for 0-5VDC output
Supply Current	35mA max.
Isolation	600VAC rms
Temperature Range	-15° to 60°C (5° to 140°F)
Humidity Range	10-90% RH non-condensing
Output	4-20mA and/or 0-5VDC
Accuracy	±3% F.S. combined linearity, hysteresis, and repeatability

The product design provides for basic insulation only.

⚠ DANGER ⚡

HAZARD OF ELECTRIC SHOCK, EXPLOSION, OR ARC FLASH

- Follow safe electrical work practices. See NFPA 70E in the USA, or applicable local codes.
- This equipment must only be installed and serviced by qualified electrical personnel.
- Read, understand and follow the instructions before installing this product.
- Turn off all power supplying equipment before working on or inside the equipment.
- Use a properly rated voltage sensing device to confirm power is off.
DO NOT DEPEND ON THIS PRODUCT FOR VOLTAGE INDICATION
- Only install this product on insulated conductors.

Failure to follow these instructions will result in death or serious injury.

NOTICE

- This product is not intended for life or safety applications.
- Do not install this product in hazardous or classified locations.
- The installer is responsible for conformance to all applicable codes.
- Mount this product inside a suitable fire and electrical enclosure.

QUICK INSTALL

1. Disconnect and lock out power to the conductor to be monitored.
2. Choose a location for the sensor. The monitored conductor must pass through the iris, and the sensor must be at least 1/2" from any uninsulated conductors.
3. Install the adjustable mounting bracket to the back of the enclosure using the included screws.
4. Connect supply voltage wires to the terminals marked Power (+) and Gnd (-).
5. Wire the output (mA or VDC) connections between the sensor and the controller.
6. Snap the sensor over the conductor to be monitored and clip the assembly to the mounting bracket.
7. Set the field-selectable switch to the desired amperage level (see page 2).

DIMENSIONS

WIRING EXAMPLE

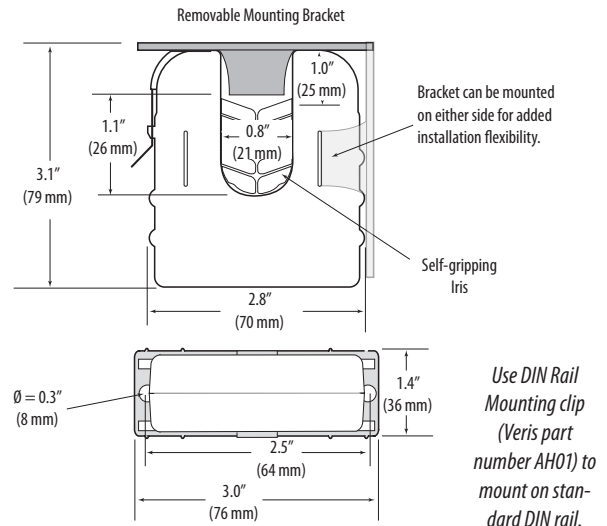
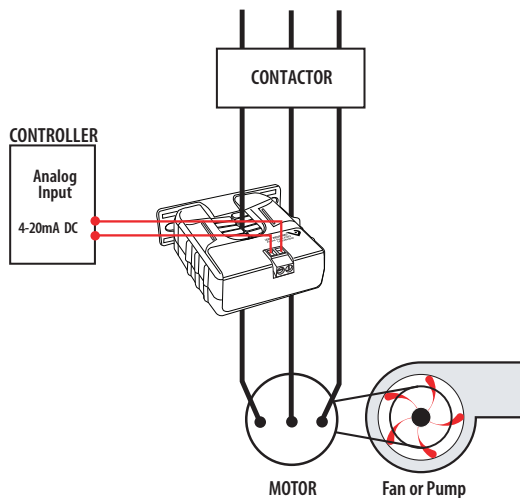

OPERATION

The H970HCA is a current-sensitive device that monitors DC current (amperage) in the conductor passing through it. The unit combines a Hall Effect sensor with proven transducer circuitry, with a status output suitable for connection to building controllers or other appropriate data acquisition equipment operating at up to 30 volts. The H970HCA requires supply voltage to generate its output. Selectable amperage ranges and output types maximize the installation flexibility.

The H970HCA housing offers unprecedented mounting flexibility. The mounting bracket can be attached in three different places. Additionally, the bracket is compatible with the Veris AH01 DIN Rail clip, allowing DIN mounting.

NOTES

For load currents less than sensor minimum rating:

Wrap the monitored conductor through the center hole and around the sensor body to produce multiple turns through the "window." This increases the current measured by the transducer.

Controller must be programmed to account for the extra turns. e.g., if four turns pass through the sensor (as shown) the normal controller reading must be divided by 4.

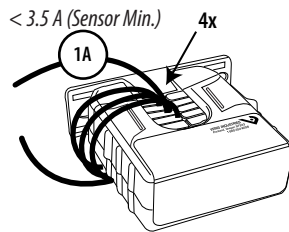

SET-UP AND WIRING

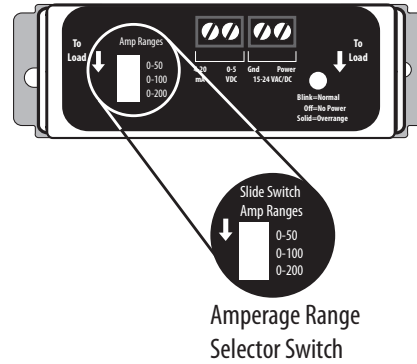

Amperage Range Selector Switch

Wiring Diagram

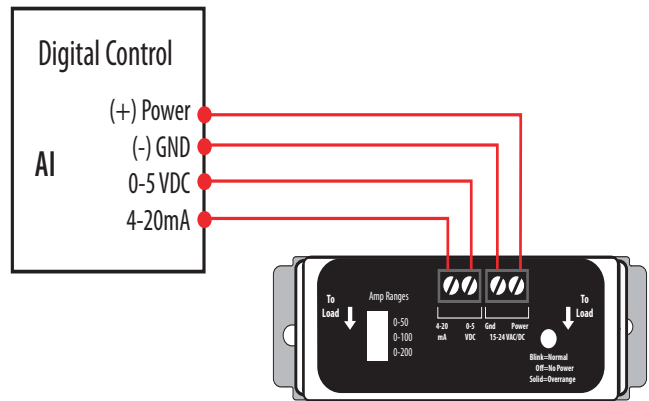

CAUTION

RISK OF EQUIPMENT DAMAGE

- Derate the product's maximum current for the number of turns through the sensing window using the following formula.

$$\text{Rated Max. Amps} \div \text{Number of Turns} = \text{Max. monitored Amps}$$
 e.g. : $100A \div 4 \text{ Turns} = 25 \text{ Amps max. in monitored conductor}$
- Failure to follow these instructions can result in overheating and permanent equipment damage.

Failure to observe the following can result in distorted product calibration:

1. Observe the arrow on the product showing orientation to current source.
2. Do not expose the product to current levels greater than the maximum amperage range.

SCALING

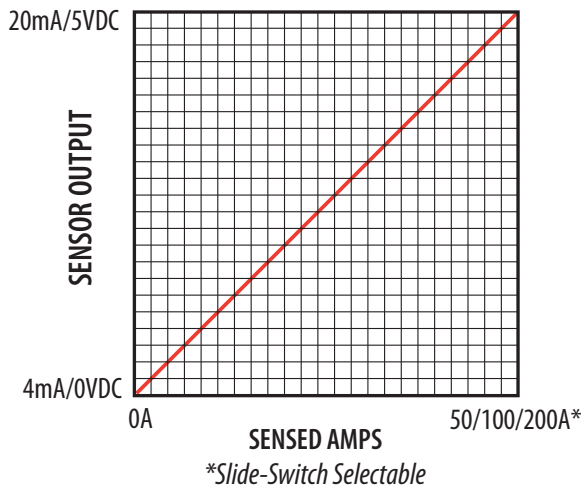

TROUBLESHOOTING

Problem	Solution
The LED is off and no signal is produced	Verify that power is applied to PWR (+) and GND (-) terminals
The LED is on solid and the output is at maximum	Verify that the amperage range selection switch is in the proper position for the current applied to the conductor.