

# H614



# Hawkeye™ 614

**Split-Core Current Switch, Auto Calibrating,  
For VFD Applications, 12 to 115 Hz**

### Specifications

|                                     |  |
|-------------------------------------|--|
| Sensor Power                        | Induced from monitored current   |
| Amperage Range                      | 1.5 to 150A Continuous   |
| Status Output                       | N.O. 1.0A@30VAC/DC   |
| Response Time                       | 1 second   |
| Learn Time                          | 15 seconds after frequency ramping stabilizes                                |
| Frequency                           | 12 to 115 Hz   |
| Temperature Range                   | -15° to 60°C (5° to 140°F)   |
| Humidity Range                      | 10-90% RH non-condensing   |
| Alarm Limits                        | ±20% of learned current in every 5 Hz freq. band                             |
| Normal-to-Alarm Status Output Delay | 5 sec. max.  |
| Alarm-to-Normal Status Output Delay | 1 sec. nominal*  |
| Off Delay                           | <30 sec (nominal)  |
| Contact Ratings                     | 30VAC/DC, 1A   |
| Insulation Class                    | 600VAC (UL); 300VAC (CE)   |
| Terminal Block Maximum Wire Size    | 14 AWG   |
| Terminal Block Torque               | 3.54 to 4.43 in-lbs (0.4 to 0.5 N-m)   |
| Agency Approvals                    | UL 508, CE: EN61010-1:2001,<br>Installation Category III, pollution degree 2 |

\* If the H614 experiences a momentary loss of power, the Alarm-to-Normal output delay may exceed 1 sec.

Specification Note: For CE compliance, conductor shall be insulated according to IEC 61010-1:2001. The product design provides for basic insulation only. Use wire with minimum 75°C rated insulation. Do not use the LED status indicators as evidence of applied voltage.

This sensor detects abnormal operation by looking for sudden changes in current across the entire frequency range. In Learn mode, the sensor calculates a margin 20% above and 20% below the learned frequency curve. An abnormal condition in the circuit is one that falls outside this margin.

## ⚡ ⚠ DANGER

### HAZARD OF ELECTRIC SHOCK, EXPLOSION, OR ARC FLASH

- Follow safe electrical work practices. See NFPA 70E in the USA, or applicable local codes.
- This equipment must only be installed and serviced by qualified electrical personnel.
- Read, understand and follow the instructions before installing this product.
- Turn off all power supplying equipment before working on or inside the equipment.
- Use a properly rated voltage sensing device to confirm power is off.
- DO NOT DEPEND ON THIS PRODUCT FOR VOLTAGE INDICATION**
- Only install this product on insulated conductors.

**Failure to follow these instructions will result in death or serious injury.**

A qualified person is one who has skills and knowledge related to the construction and operation of this electrical equipment and the installation, and has received safety training to recognize and avoid the hazards involved. NEC2009 Article 100

No responsibility is assumed by Veris Industries for any consequences arising out of the use of this material.

## NOTICE

- This product is not intended for life or safety applications.
- Do not install this product in hazardous or classified locations.
- The installer is responsible for conformance to all applicable codes.
- Mount this product inside a suitable fire and electrical enclosure.

## INSTALLATION

- Establish normal operating conditions for the VFD (clean filter, normal load, etc.).
- Disconnect and lock out power to the VFD, the enclosure, and the conductor to be monitored.
- Choose a location for the sensor. The monitored conductor must pass through the center window, and the sensor must be at least 1/2" from any uninsulated conductors. Mount the sensor on the load side output conductor of the Variable Frequency Drive. Do not install on VFD input power conductors. If using a bypass system, place the H614 between the VFD and the bypass device.
- Install the mounting bracket in the enclosure using the included screws.
- Wire the connections between the sensor and the controller.
- Snap the sensor over the conductor to be monitored. Snap the unit with the bracket latched securely to ensure proper operation.
- Restore power to the VFD and the conductor.
- As the VFD frequency ramps up, the sensor enters Learn mode. The LED will blink (alternating red-green).
- 15 seconds after the VFD frequency ramping is complete, the sensor self-calibration is finished. The LED will blink (green only).

Note: If the VFD current does not change during the Learn mode period, the sensor will not learn normal conditions. The LED will blink (green, 5 times per second) to indicate the sensor is in Status Only mode, monitoring the circuit for on/off status.

## WIRING EXAMPLE

NOTE: The H614 is not intended for use in staged pump or variable inlet vane applications.

NOTE: (Optional) For added sensitivity in detecting amperage changes, use H614 devices on all three phases of the VFD (see Operation section for details).

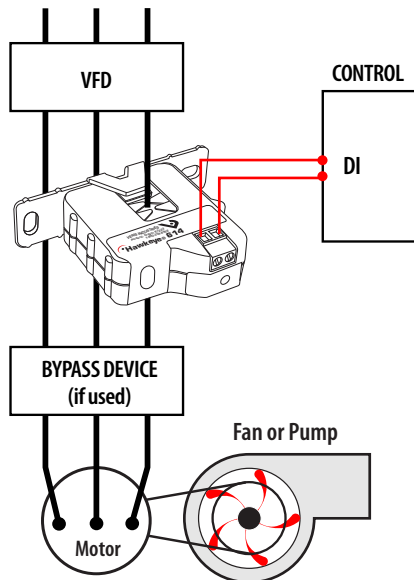

**DIMENSIONS**

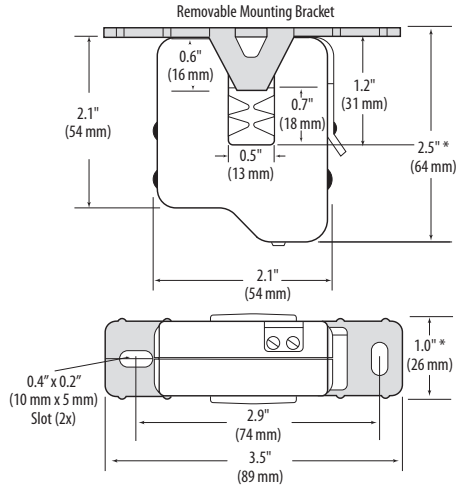

**OPERATION**

The H614 is a current-sensitive switching device designed for use with VFD systems. It is equipped with an auto calibration feature that allows the device to distinguish between a reduced amp draw due to normal changes in frequency and an abnormal drop due to belt loss or other mechanical failures.

The H614 is designed for HVAC fan and blower systems, as well as some pumping systems involving consistent viscosity liquids. If an H614 is installed on one phase of the VFD, it detects changes in that phase that result from the VFD compensating for changes elsewhere in the system. Alternatively, for increased sensitivity, H614s can be used on all three phases for immediate detection of amperage changes anywhere in the system.

A change from the normal amperage and frequency profile in the monitored conductor will cause the resistance of the FET status output to change state, similar to the action of a mechanical switch. The status output is suitable for connection to building controllers or other appropriate data acquisition equipment operating at up to 30 volts. The H614 requires no external power supply to generate its output.

Performance of the H614 can be optimized through an optional step. When the H614 is first powered and is in Learn Mode, manually cycle through each 5 Hz frequency band, allowing the VFD to remain at each band for 15 seconds.

**NOTES**

**CAUTION**

**RISK OF EQUIPMENT DAMAGE**

- Derate the product's maximum current for the number of turns through the sensing window using the following formula.  
**Rated Max. Amps ÷ Number of Turns = Max. monitored Amps**  
 e.g. : 100A ÷ 4 Turns = 25 Amps max. in monitored conductor
- Failure to follow these instructions can result in overheating and permanent equipment damage.

*For load currents less than sensor minimum rating:*

Wrap the monitored conductor through the center window and around the sensor body to produce multiple turns. This increases the current measured by the transducer.

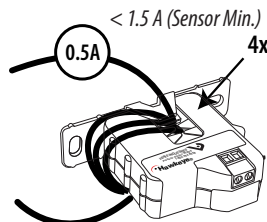

**STATUS LEDs**

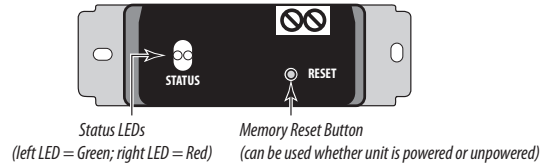

| Sensor Mode   | Status LED Blink Pattern  |
|---|---|
| Learning Mode (first 15 sec of operation after frequency stabilizes)                                      | Alternating Red/Green (1 per sec.)                              |
| On/Off Status only; Learn mode incomplete. VFD system does not meet abnormal condition detection criteria | Green blink (5 times per sec. after 15 sec of stable frequency) |
| Status OK   | Green blink (1 per sec.)  |
| Alarm   | Red blink (1 per sec.)  |

**MEMORY RESET**

During setup, the H614 automatically determines the normal amperage and frequency profile and stores it in nonvolatile memory. The H614 requires a Memory Reset to clear the nonvolatile memory if any of the following conditions occur:

- The sensor is reinstalled on a different motor.
- The motor is re-sheaved.
- The system is air balanced or air duct restrictions change
- The motor load changes significantly.

To reset the H614:

- Establish normal operating conditions for the monitored conductor (e.g. clean air filters, close duct access doors).
- The Reset switching button has two positions, in and out. Push the button until there is a noticeable click to change the position of this switch. This causes a change of state, which triggers the Reset function. The nonvolatile memory is erased and the H614 will enter the Learning mode (LEDs blink red/green) to learn the new amperage profile of the monitored conductor.

**Note:** The Reset function can be performed even if the H614 is not installed on a conductor. Pushing the button (changing the state) will clear the nonvolatile memory at the next power-up.

**Note:** For normal operation, this button can be in either in or out position.

**TROUBLESHOOTING**

| Problem                         | Solution   |
|---------------------------------|--|
| No LED or Incomplete Learn mode | <ul style="list-style-type: none"> <li>Check for amperage in monitored conductor (&gt;1.5 A).</li> <li>Check that amperage in the monitored conductor does not exceed sensor max (150 A).</li> <li>Ensure that no more than 30 VAC/DC or 1.0A has passed through the contact. Voltages or currents above these levels will damage the unit.</li> <li>Ensure that sensor core mating surfaces are clean and that the core clamp is completely closed.</li> <li>Ensure that the sensor is operating within specified temperature range.</li> <li>Ensure that the sensor has completed Learn mode. If it has not, check circuit parameters and compliance.</li> </ul> |