

Current Switch: Auto Calibration, Automation Systems

LCD Display



DESCRIPTION

The Hawkeye TruStat H11D is a microprocessor based, self-learning, self-calibrating current switch. It is designed for user ease, providing calibration-free status for both under and overcurrent, an LCD display, and slide-switch selectable trip point limits. At initial power-up, the H11D automatically learns the average current on the line with no action required by the installer. Once a current is learned, the switch monitors for changes in current greater than the selected range.

APPLICATIONS

- HVAC fans, pumps, and blowers
- Monitoring status of industrial process equipment



SPECIFICATIONS



Sensor Power	Induced from monitored conductor
Response Time	1 sec.
Accuracy	±2% of full scale
Frequency Range	50/60 Hz
Temperature Range	-15° to 60°C (5° to 140°F)
Humidity Range	10-90% RH non-condensing
LCD Backlight	Off at low currents; illuminates when monitored current exceeds 4.5A; flashes during an alarm state while current remains above 4.5A
On-State Resistance	≤1.0 Ω
Off-State Resistance	≥1.0 MΩ
Setpoint Target Range, Switch Setting A*	±40% of learned nominal current; max. learned current of 142A to enable an upper trip limit at or below 200A
Setpoint Target Range, Switch Setting B*	±60% of learned nominal current; max. learned current of 125A to enable an upper trip limit at or below 200A
Switch Setting C*	On/Off Status; contacts are closed while amperage is above 2.5A
Alarm Reset Range	±5% of learned nominal current **
Setpoint Calibration Learn Period	30 sec.; self-learning, pushbutton reset
Normal-to-Alarm Output Delay	1 sec. maximum
Alarm-to-Normal Output Delay	30 sec. nominal
Insulation Class	600VAC RMS (UL); 300VAC RMS (CE)
Terminal Block Wire Size	24-14 AWG (0.2 to 2.1 mm ²)
Terminal Block Torque	3.5 to 4.4 in-lbs (0.4 to 0.5 N-m)
Agency Approvals	UL508 open device, CE: EN61010-1:2001-02, CAT III, pollution degree 2

* Trip point switch positions A and B are not for use in applications where the current will fluctuate by more than 40% (A) or 60% (B) of the nominal current. If the current will fluctuate by more than 60%, use the H11D for on/off status (position C) only.

** The upper trip limit alarm resets when the current drops by 5% of the learned nominal current limit. The lower trip limit alarm resets when the current rises by 5% of learned nominal current limit.

Specification Note: For CE compliance, conductor shall be insulated according to IEC 61010-1:2001.

The product design provides for basic insulation only.

Do not use the LCD as evidence of applied voltage.

FEATURES

- Backlit LCD display...view the monitored current (up to 200A)...eliminates the need for expensive handheld meters and offers easy visibility in dark enclosures
- Automatic calibration...reduced errors and installation costs
- Slide-switch selectable trip point limits...application versatility
- Microcontroller based learning technology...automatically learns load upon initial power-up...eliminates labor associated with calibration
- Records and displays the amperage level that trips the alarm...simplifies troubleshooting
- Reset function can be used when unpowered...reduces the possibility of an undesirable arc flash incident
- Monitors current for both under- and over-load in one package
- 100% solid state...no moving parts to fail
- Small size fits easily inside small starter enclosures...saves space
- Self-gripping iris for easy installation
- Bracket can be installed in three different configurations...added flexibility
- 5-year warranty

DIMENSIONAL DRAWING

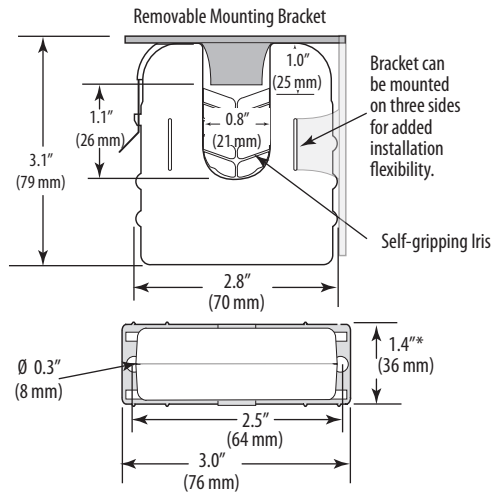

APPLICATION/WIRING DIAGRAM

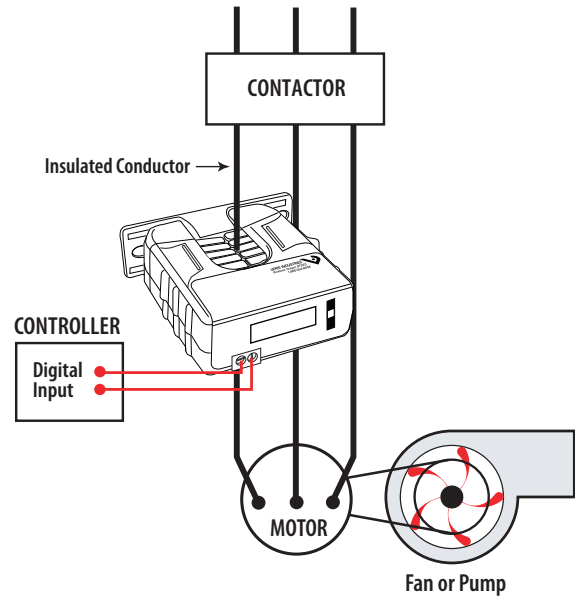

FUNCTIONAL ILLUSTRATION

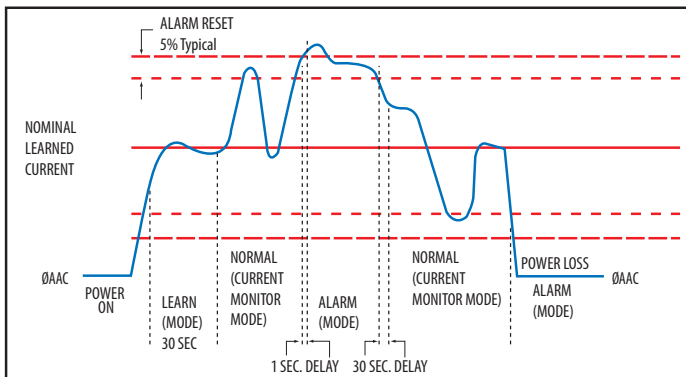

ORDERING INFORMATION



MODEL	AMPERAGE RANGE ¹	STATUS OUTPUT	NOMINAL TRIP POINT TARGET RANGE	HOUSING	STATUS LED	UL	CE
H11D	2.5 - 200A @ 60 Hz 3.0 - 200A @ 50 Hz	N.O. 1.0A@30VAC/DC	±40%, ±60%, or on/off (user selectable)	Split-core	●	● ²	●

¹ To enable the upper trip limit alarm, the max. learned current for switch setting "A" is 142A, and the max. learned current for switch setting "B" is 125A. Switch setting "C" is for on/off status only, so the upper trip limit alarm does not apply.

² Listed for use on 75°C insulated conductors.

ACCESSORIES

DIN Rail Clip Set (AH01)

DIN Rail (AV01) and DIN Stop Clip (AV02)

