

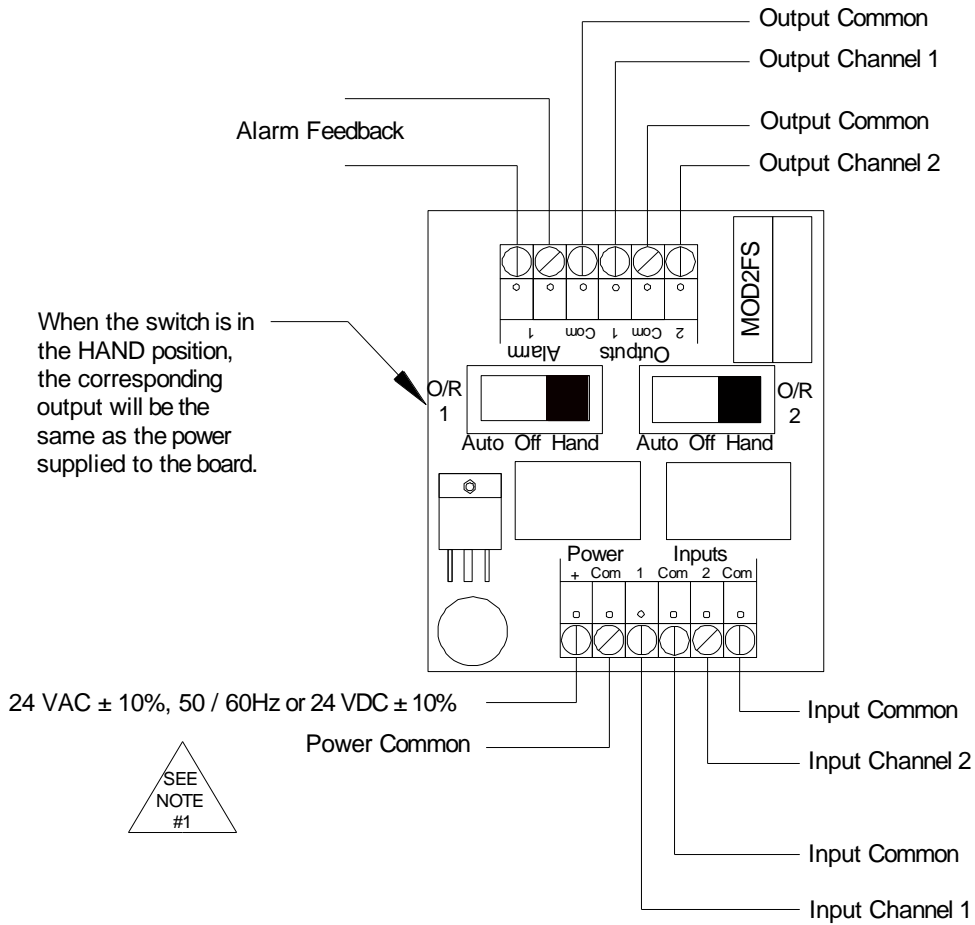

## Installation and Operation Instructions MDO2FS

### Fail safe Two Channel Manual Digital Override w/ Feedback



## INSTALLATION

### READ THESE INSTRUCTIONS BEFORE YOU BEGIN INSTALLATION.

Ground yourself to discharge static electricity before touching any electronic equipment, as some components are static sensitive.

#### **MOUNTING:**

The interface device can be mounted in any position. If circuit board slides out of the snap track, a nonconductive “stop” may be required. Use only fingers to remove the board from the snap track. Slide out of snap track or push up against side of snap track and lift that side of the circuit board to remove.

#### **POWER CONNECTIONS:**

Be sure to follow all local and electrical codes. Refer to wiring diagram for connection information.

1. **24 VDC** – with power off, connect 24 volt DC power supply to terminals PWR (+) and C (-) on the board.  
**24 VAC** – with power off, connect one transformer secondary leg to the PWR (+) on the board. Connect the other transformer secondary leg to POWER COM. Check the wiring configuration of any other loads that may be connected to this transformer.  
 If required by BAS or controller specification, the 24 VAC neutral can be earth grounded at the transformer. Analog input, digital input, and analog output circuits should not be earth grounded at two points. Any field device connected to this transformer must use the same common. If you are not sure of other field device configuration, use separate transformers for isolation.
2. **If the 24 volt DC or AC power is shared** with other devices that have coils such as relays, solenoids, or other inductors, each coil must have a diode or DC Transorb (if DC), a MOV or AC Transorb (if AC), or other spike snubbing device across each of the shared coils. Without these snubbers, coils produce very large voltage spikes when de-energizing that can cause malfunction or destruction of electronic circuits.
3. You should measure the actual voltage output of the secondary. If the output is not fully loaded you may read a higher voltage than the circuit board can handle.

## **CALIBRATION AND CHECKOUT**

---

1. Connect the power supply HOT to the “+” terminal and COMMON to the “COM” terminal.
2. Connect signal input (+) to Inputs 1 and 2 and signal input common to corresponding “COM”. Connect controlled device signal (+) to Override Outputs 1 and 2 and common to signal “COM”. Connect alarm Feedback if used.
3. To obtain the input signal on the output signal connections, set switches in the “AUTO” position. Corresponding inputs are routed to corresponding outputs.

### **Operation:**

4. Apply power to the MDO2FS.
5. When the switch is in the AUTO position, the corresponding input is routed directly to its corresponding output.
6. When the switch is in the OFF position, the corresponding input is disconnected from its corresponding output and the output should be zero volts.
7. When the switch is in the HAND position, the corresponding output will be the same as the power supplied to the board.
8. When either switch is in the OFF or HAND positions the Alarm Feedback will be a contact closure. (Resistive feedback available upon request.)
9. When power is lost to the MDO2FS, the unit will fail back to the building automation system signal regardless of HOA switch position.

**Signal Input:** 24 VAC  $\pm$  10% 50/60 Hz, 24VDC  $\pm$  10%

**Signal Input Current:** 4 Amp maximum

**Signal Output:** Same as signal input

**Signal Output Current:** Same as input with switches in AUTO position. 4A maximum with switches in HAND position providing the power supply can provide 4 Amps to the MDO2FS

**Alarm Feedback:** Standard: N.O in AUTO operation  
 (Optional: N.O. in HAND/OFF operation)

**Switch Closure:** 2 Amps maximum @ 24 VAC/VDC  
 Optional resistive feedback, 3 W max.