

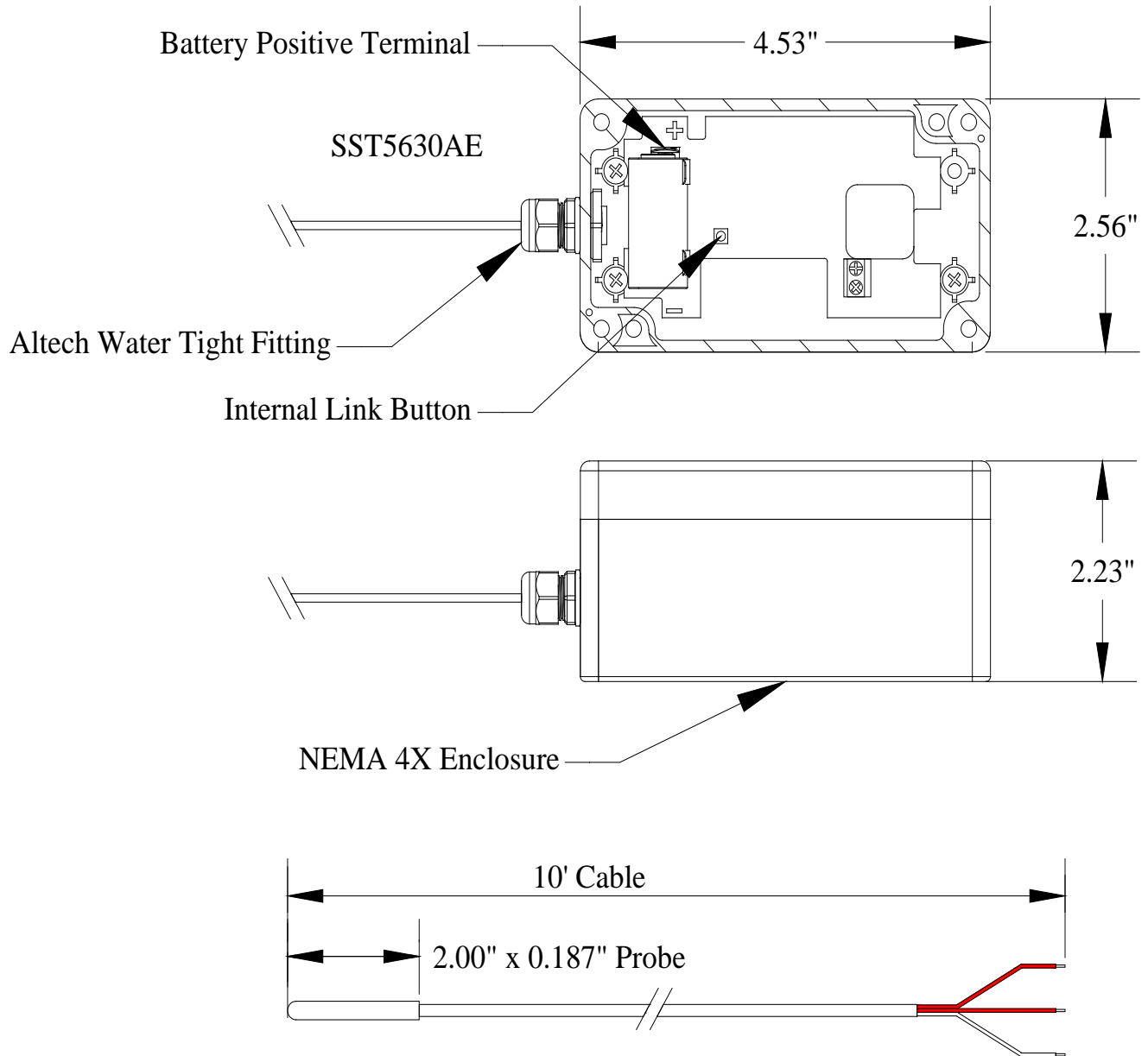

# Installation and Operation Instructions SST5630 Wireless Remote/Strap-On Temperature Sensors



## General Description

The mesh network Series 2000 SST5630 is a battery operated spread spectrum wireless remote/strap-on temperature sensor. It is designed for monitoring temperature on pipes where an immersion sensor cannot be installed.

The RTD sensor is encapsulated in a 0.187" O.D. 304 stainless steel probe (2" probe length) for single point pipe temperature monitoring.

ACI's mesh network Series 2000 wireless sensors utilize reliable Spread Spectrum Radio technology. They can be installed easily in minutes eliminating hundreds of feet of wire and saving installation cost while reducing installation labor risks.

The Series 2000 sensor Data-Link LED confirms the data transmission was received by the receiver for fast and reliable positioning of the sensor during installation. *There is no need for special wireless installation equipment or tool.*

Together with the ACI Series 2000 receivers and controllers, the ACI wireless sensors can be used with any LON, BacNet, MODbus, or DDC control system or panel.

The maximum radio transmission distance is dependent on the building type. The maximum open air transmission distance is one mile. In a typical commercial building with steel I-Beam construction, concrete floors with reinforcing rod, and metal stud walls, it can be expected that transmissions will penetrate vertically through floors and horizontally through 200 to 500 feet of walls, furniture and air.

## Installation

Wireless remote/strap-on sensors should be installed within 200 to 500 feet of the receiver. RR2552 signal repeaters can be installed as needed to increase transmission distance between sensors and receivers.



### CAUTION

**Observe battery polarity when installing battery.**

To select the proper sensor location, *first install and power the receiver. To activate the sensor insert the battery observing the polarity.* The mesh networked Series 2000 system does not require any additional wireless equipment to determine the proper location of the sensors.

While the sensor is attempting to connect to the receiver the Data-Link LED will blink rapidly 8–10 times every 10 seconds. Once a connection has been established, the Data-Link LED will blink once to indicate the data transmission has been received successfully. The Data-Link LED will continue to blink once for every data transmission. The data transmission rate is programmed into the sensor (normally 1 minute intervals). To manually initiate a data transmission press the push button switch located by the negative terminal of the battery.

The sensor probe should be mounted under any insulation in direct contact with the pipe using metal pipe straps. For proper measurement of temperature, thermal conductive compound should be used in between the sensor probe and the pipe. The installation should be wrapped with insulation to reduce the effect of ambient air. The plastic housing of the sensor can either be mounted on the pipe with metal pipe strap or wall mounted.

Locate and record the sensor ID numbers located on a label inside the unit prior to mounting.

The sensor has a Low Battery LED that will start to blink continuously when the battery voltage is low. A low battery signal is also sent to the receiver for remote indication that the battery should be replaced. If the battery is not replaced in approximately 2 months, the battery voltage will become so low that the Low Battery and Data-Link LEDs will not blink. Replace the battery and the Data-Link LED will start blinking while the sensor is re-establishing communications with the receiver.

Then attach the cover of the sensor by installing the four screws.



## PRECAUTIONS

**SENSORS, REPEATERS AND RECEIVERS SHOULD NOT BE INSTALLED IN THE FOLLOWING AREAS:**

- **INSIDE METAL ENCLOSURE / PANEL**
- **INSIDE OR IMMEDIATELY NEXT TO ELEVATOR SHAFT / ELEVATOR BANKS**
- **IN FRONT OF OR IMMEDIATELY NEXT TO LARGE TREES OR LARGE BODY OF WATER**

**TRANSMISSION DISTANCE AND PERFORMANCE WILL BE DRASTICALLY REDUCED.**



## CAUTION

**DO NOT USE THIS PRODUCT IN ANY SAFETY RELATED APPLICATIONS WHERE HUMAN LIFE MAY BE AFFECTED.**

## PRODUCT SPECIFICATIONS

<b>Supply</b>	<b>Voltage</b>	(1) Li/MnO2 3.0 VDC Battery, 1400 mAH (e.g. Duracell DL123A)
<b>RF</b>	<b>Data Protocol</b>	IEEE 802.15.4-2003/2006
	<b>Operating Frequency</b>	902-928 MHz
	<b>Output Power</b>	+11 dBm
	<b>Receiver Sensitivity</b>	-110 dBm
	<b>Open Field Range</b>	One mile (line of sight)
	<b>Data Transmission Interval</b>	75 seconds (standard), 300 seconds (option)
<b>Temperature</b>	<b>Accuracy</b>	± 3°F
	<b>Sensor Operating Range</b>	-300 to 300°F (-184 to 149°C)
<b>Features</b>	<b>User Interface</b>	10' (3.1m) sensor cable length and External Link Button (optional)
<b>Enclosure</b>	<b>Material</b>	Polycarbonate (Nema 4X)
	<b>Rating</b>	UL 94 HB (Nema 4X)
<b>Environment</b>	<b>Operating Temperature</b>	14 to 140F (-10 to 60°C)
	<b>Operating Humidity</b>	5 to 95% RH (non-condensing)
<b>Approvals</b>		FCC

## WARRANTY SPECIFICATION

The ACI Wireless Series is covered by ACI's Two (2) Year Limited Warranty, which is located in the front of ACI'S SENSORS & TRANSMITTERS CATALOG or can be found on ACI's web site: [www.workaci.com](http://www.workaci.com).