

Please Read Instructions Carefully Before Installation!

■ Safety

- ⚠ • This product is not intended to be used for Life or Safety applications.
- ⚠ • This product is not intended for use in any hazardous or classified locations.
- ⚡ • Disconnect and lock out all power sources before installation as severe injury or death may result from electrical shock due to contact with high voltage wires.

■ Installation

Disconnect and lock out all power sources before installation as severe injury or death may result from electrical shock due to contact with high voltage wires. Make sure that all installations are in compliance with all national and local electrical codes. Only qualified individuals that are familiar with codes, standards, and proper safety procedures for high-voltage installations should attempt installation. The current sensor will not require external power, since the power for the current sensor is induced from the conductor being monitored.

The A/CTE & A/CTV Series Analog Current Sensors should be used on **Insulated Conductors Only!** The current sensors may be mounted in any position using the (2) #8 x 3/4" Tek screws and the mounting holes in the base or snapped directly on to the 35mm DIN rail (See Figures 1 & 2 below). Leave a minimum distance of 1" (3 cm) between the current sensor and any other magnetic devices such as contactors and transformers.

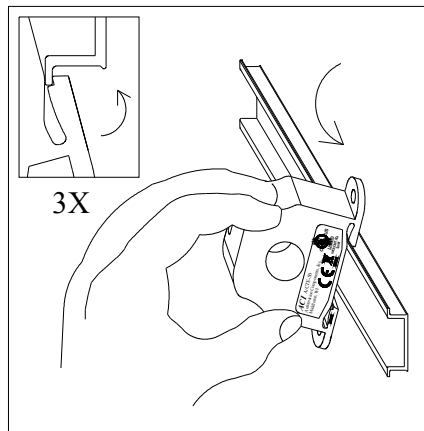

Figure 1: Sensor Placed on Rail

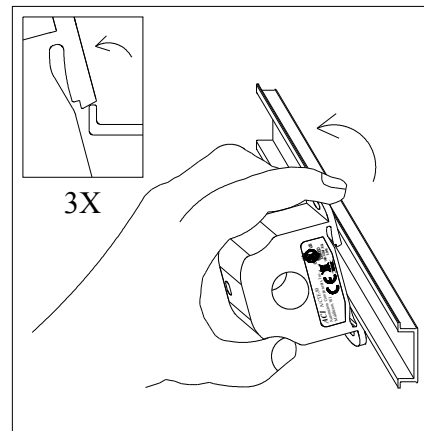

Figure 2: Sensor Removed From Rail

■ Wiring

ACI recommends the use of a 2 conductor 16 to 22 AWG shielded cable, or **copper wire only** for all Analog current sensor installations. A maximum wire length of less than 30 meters (98.4 feet) should be used between the A/CTE and A/CTV series current sensors and the Building Management System or controller. **Note: When using a shielded cable, be sure to connect only (1) end of the shield to ground at the controller. Connecting both ends of the shield to ground may cause a ground loop.** When removing the shield from the sensor end, make sure to properly trim the shield so as to prevent any chance of shorting. The current sensors terminals are polarity sensitive and represent a linear 0 to 5 or 0 to 10 VDC output signal. The recommended torque to be used on the terminal block connections is 0.67 Nm or 5.93 in-lbs. The aperture (hole) size of the current sensor is 0.75" (1.90 cm) and will accept a maximum cable diameter of 350 MCM's.

2305 Pleasant View Rd. ● Middleton Industrial Park ● Middleton, WI 53562
PH: (608) 831-2585 ● FAX (608) 831-7407

■ Operating Specifications

ACI Model #	Output	Range	Jumper *	Max. Sensing Current Voltage	Max. Continuous Current	Max. Current for 6 seconds
A/CTE-50	0 to 5 VDC	0-10 Amps 0-20 Amps 0-50 Amps	Low Middle High	600 VAC	100 Amps 150 Amps 200 Amps	125 Amps 225 Amps 300 Amps
A/CTE-250	0 to 5 VDC	0-100 Amps 0-200 Amps 0-250 Amps	Low Middle High	600 VAC	200 Amps 360 Amps 400 Amps	250 Amps 450 Amps 500 Amps
A/CTV-50	0 to 10 VDC	0-10 Amps 0-20 Amps 0-50 Amps	Low Middle High	600 VAC	60 Amps 100 Amps 160 Amps	80 Amps 200 Amps 300 Amps
A/CTV-250	0 to 10 VDC	0-100 Amps 0-200 Amps 0-250 Amps	Low Middle High	600 VAC	160 Amps 320 Amps 400 Amps	200 Amps 400 Amps 500 Amps

***Note:** All current sensors are shipped from the factory with the jumper set in the high range.

Wiring Example

Connections: Shielded, twisted pair cable is recommended for these connections.
Note: Ground shield at control system end only!

Power: These current sensors **DO NOT** need an external power source, since the power is self-induced from the monitored load or conductor.

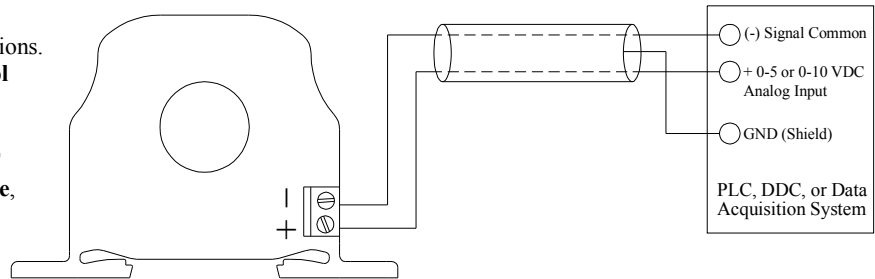

■ Troubleshooting

Problem	Solution
No reading	<ul style="list-style-type: none"> - Verify that there is current flowing thru the conductor being monitored with a clamp-on current probe. The power for the current sensor is induced from the conductor being monitored. - Check the polarity of the circuit. - Verify that the terminals are screwed down, wires are firmly in place. - Disconnect the wires from the current sensor output. Measure the voltage across the current sensor output with a Voltmeter to verify that the sensor is working properly.
Erratic readings	<ul style="list-style-type: none"> - Verify that the wires are terminated properly. - In areas of high RF interference, shielded cable may be necessary to stabilize signal.
Inaccurate readings	<ul style="list-style-type: none"> - If you suspect that the current sensor is not reading within the accuracy specifications, please contact the factory for assistance.

■ Current Conversion Formulas

To convert the current sensor output signal to a current reading.

0-10 Volt output to Current reading (0 Volts = 0 Amps and 10 Volts = 250 Amps for A/CTV-250)

Example: 5 Volts current sensor output signal

Total Span = 250 Amps

Multiplier = $10V-0V/\text{Total Span} = .04$

$(5 \text{ Volts}) / 0.04 = \mathbf{125 \text{ Amps}}$

2305 Pleasant View Rd. ● Middleton Industrial Park ● Middleton, WI 53562
PH: (608) 831-2585 ● FAX (608) 831-7407

■ **WEEE Directive**

At the end of their useful life the packaging and product should be disposed of via a suitable recycling centre. Do not dispose of with household waste. Do not burn.



2305 Pleasant View Rd. ● Middleton Industrial Park ● Middleton, WI 53562
PH: (608) 831-2585 ● FAX (608) 831-7407