

Flexible I/O Module

A8332-8F2D

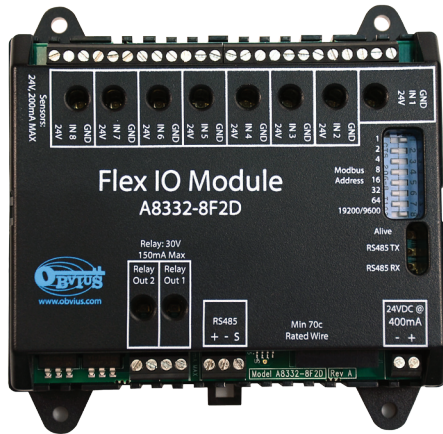

A8332-8F2D

SPECIFICATIONS



Processor	ARM 7, field upgradable firmware
LED	8 input status LEDs (red), 2 Modbus TX/RX (yellow), 1 power/alive status (green)
Protocols	Modbus/ RTU
Power Supply	24VDC, 200mA (not included)
Serial Port	RS-485 Modbus, 19200 or 9600 baud. N81
Inputs	8x, user selectable; 0-10V: Min/Max/Ave/Instantaneous; 4-20mA: Min/Max/Ave/Instantaneous; Pulse: Consumption, Rate; Resistance: 0-10V: Min/Max/Ave/Instantaneous
Maximum Pulse Rate	10 Hz
Contact Closure Threshold	1 kΩ
Isolation	RS-485 port is optically isolated
OPERATING ENVIRONMENT	
North America	Indoor, -30° to 70°C (32° to 122°F), 0-95% RH noncondensing

Pulse/Analog To Modbus® Converter

FEATURES

- Network up to 8 industry-standard sensors to the AcquiSuite data acquisition network
- Universal inputs simplify setup...just connect sensors and select device output type via the AcquiSuite or using Obvius configuration software
- Check device status at a glance...LED indicators allow for fast recognition of on/off status, TX/RX communications, and 8 input notifications
- Field-selectable address DIP switch...no software or PC configuration required
- High reliability...nonvolatile memory retains configuration and pulse data during power failures
- All configuration information and input data is stored in non-volatile memory to prevent data loss in the event of power failure
- 8 user selectable universal inputs to aggregate analog, pulse, and resistance sensors/meters

DESCRIPTION

The **A8332-8F2D** Input Module provides a convenient way to optimize energy use and accurately allocate costs. Add eight standard pulse and/or analog sensors to a data acquisition network. Integrate your Veris network sensors through the A8332-8F2D to a Veris H8822 Data Acquisition Server.

The A8332-8F2D is the first truly flexible input module that allows incorporation of virtually any industry-standard sensor through a single device. The module can be incorporated with cost-effective data acquisition and wireless metering solutions such as the H8822 AcquiSuite DR™ server, which, as a properly integrated system, provides high performance and low cost. This system can be incorporated into a new or existing Building Automation System (BAS). Using the AcquiSuite data acquisition system, users can set input types (pulse, analog, resistive, etc.), giving access to real time resource consumption for a facility on a single board.

APPLICATIONS

- Demand response program control and reporting
- Cost allocation to tenants and third parties
- Measurement and verification of energy savings
- Converting pulse inputs from water and gas flow meters to a Modbus network
- Monitoring performance of building systems (e.g., chillers, boilers, fans)

APPLICATION EXAMPLES

DIMENSIONAL DRAWING

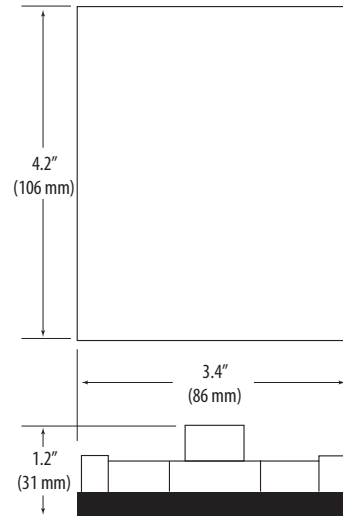
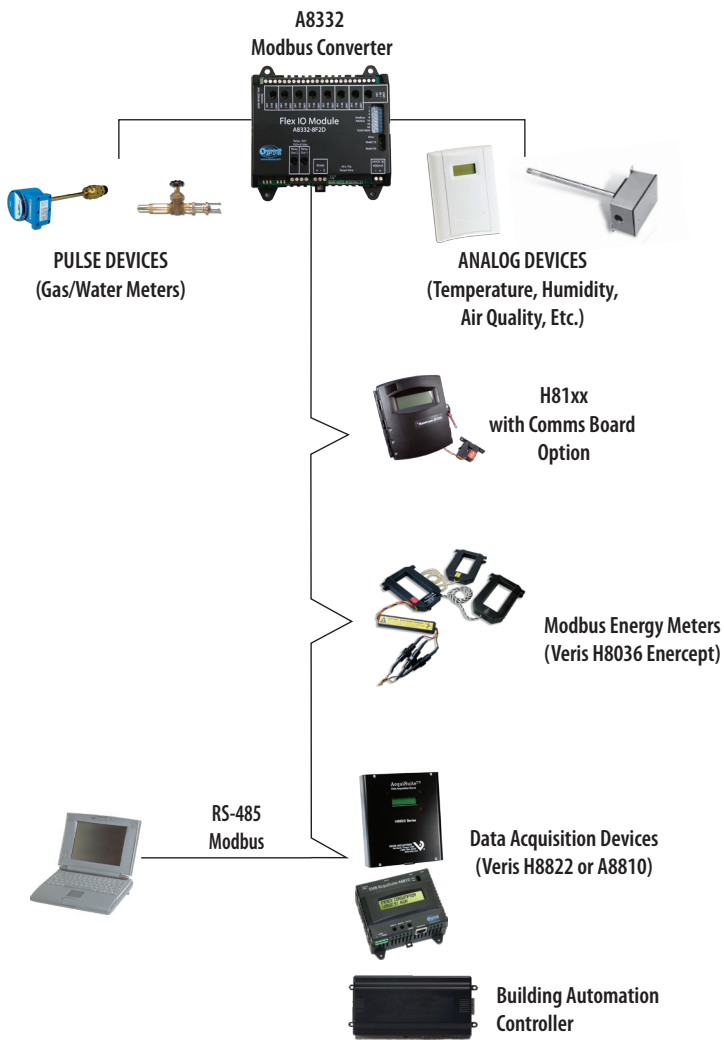

ORDERING INFORMATION

MODEL	MANUF. PART #	DESCRIPTION
U013-0011	A8332-8F2D	Flexible I/O Module